

Radio
**SERVICE
DEALER**

APRIL, 1949



IN THIS ISSUE:

New TV Test Equipment
AM-FM Signal Generator Design
Phase Inversion, Part 2
Custom Building for High Fidelity
Miniature Tube Chart
Test Equipment Charts
New TV Quiz Series

AM-FM-TV-SOUND

The Professional Radioman's Magazine

Quiet as a **MOUSE!**



The Mallory Midgetrol

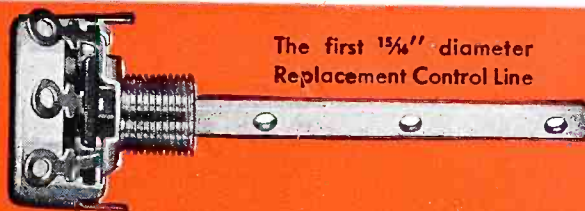

The first $1\frac{1}{8}$ " diameter Replacement Control Line

Quietest by actual test!—that's the Mallory Midgetrol. Tests made on the ultra-sensitive sound testing meters built for the Navy prove that its noise level in radio applications is so low as to be totally inaudible.

Low noise level, long life, accurate resistance values and smooth, uniform tapers—all the things you want in a volume control—you get from the Mallory Midgetrol!

LOOK WHAT THE MALLORY MIDGETROL OFFERS:

WIDER APPLICATION—The small size allows you to service portables, auto radios and small AC-DC receivers requiring $15/16$ " controls.

SIMPLER INSTALLATION—The new and unique flat shaft design of the Mallory Midgetrol saves installation time with *all* types of knobs.

LESS INVENTORY—Electrical characteristics allow you to use the Mallory Midgetrol to replace $1\frac{1}{8}$ " as well as $15/16$ " controls. Since no special shafts are required, you carry fewer controls in stock.

NEW SIZE
NEW DESIGN

NEW SHAFT
NEW EXTENSION

NEW SWITCH
NEW ELEMENT

NEW CONTACT
NEW TERMINAL

NEW TWO-POINT SUSPENSION

See your Mallory Distributor for this new standard in carbon controls

P. R. MALLORY & CO. Inc.
MALLORY

CAPACITORS... CONTROLS... VIBRATORS...
SWITCHES... RESISTORS... RECTIFIERS...
VIBRA-PACK* POWER SUPPLIES... FILTERS

*Reg. U. S. Pat. Off.

APPROVED PRECISION PRODUCTS

P. R. MALLORY & CO., Inc., INDIANAPOLIS 6, INDIANA

Here's what
radio men
say about

SYLVANIA'S DEALER CAMPAIGNS



PHONE: ARMO
SHOOTERS
DEPENDABLE
MIKE'S
RADIO AND TELEVISION SERVICE
EXPERT SERVICE ON ALL MAKES
10523 1/2 WEST PICO
LOS ANGELES, CAL.

November 1, 1948

Advertising Department
Sylvania Electric Products Inc.
Emporium, Pa.

Gentlemen:

I would like this opportunity to tell you how much the Sylvania co-ordinated advertising campaign has helped my business.

Although I have used direct mail postal cards in the past for soliciting new business, the tie-in with national advertising offered in the Sylvania campaign was responsible for an extraordinary return. The response I have had from your campaign has been truly amazing.

As an example, I mailed 1000 postal cards in May at a cost to me of \$10.00. To date this investment has brought a return of \$352.19. During June, July and August I mailed another 1000 cards each month at a total cost of \$30.00. To date the return from this investment has amounted to \$760.46.

You will note that for a total investment of \$40.00 I have, to date, enjoyed an increase in business amounting to \$1,112.65 -- all from new customers. I can safely say that there is still more business to come from these cards in future months.

I mailed another 1000 cards to my prospect list of 12,964 names during October and November. I also expect to mail another 1000 cards during December.

Speaking for myself, I would certainly like to see this campaign become a regular 'shot in the arm' at least twice a year. It will do much to help business in the spring and early fall when business is usually slow.

Many thanks and best wishes.

Very truly yours
MIKE'S RADIO SERVICE

By *Michael Waxman*
Michael Waxman



BRING IN YOUR RADIO TUBES - WE TEST THEM FREE - DEALERS FOR Sylvania. SEE TESTED TUBES

SCURLOCK'S RADIO SHOP

ELECTRICAL APPLIANCES -- HARDWARE
EVERYTHING PERTAINING TO RADIO
SUMITON, ALABAMA

September 18, 1948

Advertising Department
Sylvania Electric Products Inc.
Emporium, Pa.

Gentlemen:

In 1937 when we started our radio repair business, we used personal postal cards to get our name before our prospective customers. For a beginner, this kind of advertising seemed a little more than we could pay, although it did wonders for our business.

We are happy that the service industry has a great company behind us with national advertising and personal postal cards. During your first co-ordinated advertising campaign we bought 1200 cards and mailed them to our customers according to Sylvania's specifications. The results were so effective that we are going to use the campaign again. We want to see if the campaign is really responsible for the extra business we are enjoying.

The "funny cards", as our customers call them, are even responsible for payment of some of our past due accounts. Our radio sales are up. We are making allowance for old radios which our customers get out for us to repair after receiving our atomic reminder card.

We want to personally thank Sylvania for taking an interest in us and giving us this low cost, yet effective, advertising.

VERY KINDLY YOURS

J. B. Scurlock
J. B. SCURLOCK

Like these service dealers you can increase your business

Sylvania's May, June, July and August campaigns are ready for you. Here's what you receive:

- 4 Postal Card Mailings—one for each month.
- 4 Window Displays—one for each month.
- 4 Window Streamers—one for each month.
- 8 Newspaper Ad Mats—two for each month.
- Radio Spot Announcements—several for each month.

Send for full details now! Remember, you pay only the postage on the government postal cards you mail. Sylvania supplies everything else free!

SYLVANIA ELECTRIC

RADIO TUBES; CATHODE RAY TUBES; ELECTRONIC DEVICES; FLUORESCENT LAMPS; FIXTURES, WIRING DEVICES; PHOTOLAMPS; LIGHT BULBS

Sylvania Electric Products Inc.
Advertising Department, R-1804
Emporium, Pa.

Gentlemen: Send full information on your May, June, July and August Service Dealer Campaigns.

Name _____
Company _____
Address _____
City _____ Zone _____
State _____

EDITORIAL

Our First Decade

This is our 10th Anniversary issue, so—Happy Birthday to us! Several thousand Service Dealers and Technicians who became "RSD" subscribers during its formative period are still on our active roster. Surveys show that: our subscribers on an average have been engaged in radio servicing for over 14 years; most are acknowledged by parts jobbers to be the leading Service Dealers in their respective communities, and last, but not least, since the advent of TV, the readers of "RSD" account for the bulk of all TV installation and maintenance work.

The radio servicing profession is known to have a extremely high business mortality rate. Only about 10% of the graduates of radio training schools continue in the field beyond 3 years. The great majority who drop out do so because radio servicing does not afford much opportunity to those who wish to get rich quickly. However, as we see it, the opportunity to earn a fine livelihood in radio-TV servicing is better now, and will increasingly become better, than ever before.

Old-time Service Dealers know that their success has been occasioned by the fact that they gave genuinely efficient service at fair prices. They won, the hard way, their place as respected professional men in their communities. Now, if the newcomers will only appreciate that they must work their way up the slow, sure way, after serving a proper apprenticeship, there will be many more Happy Birthdays ahead for all of us.

The 1949 Trade Show

Again, this year May 16 to 20th, the Radio Parts and Electronic Equipment Conference and Show will be held at the Hotel Stevens, Chicago. Attendance is restricted primarily to Parts Jobbers and Manufacturers' Representatives so they can view the new products which Manufacturers plan to market during the coming year. Our June issue will tell you all about these new items.

"Preventive Maintenance Month"

In this issue's "Field Findings" we again advocate "Preventive Maintenance Month"—a subject that should be uppermost in the minds of every Radio Service Dealer and Technician. The Radio Manufacturers' Association repeatedly sponsors a "Radio In Every Home Week" and then issues reports showing how successful their efforts have been. Now let's see what RMA will do for the radio-TV servicing profession which badly needs cooperation and support from the radio industry's "Big Brass". A "Preventive Radio Maintenance Month" venture has been tried with great success. Read all about it in "Field Findings".

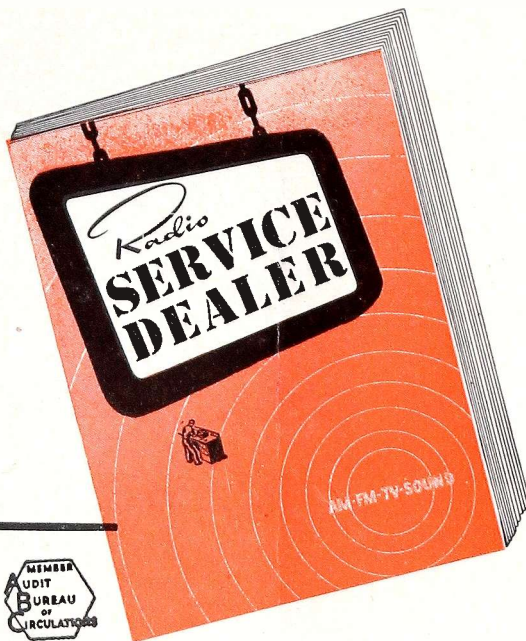

Sanford R. Cowan
EDITOR & PUBLISHER

Samuel L. Marshall
MANAGING EDITOR

COWAN PUBLISHING Corp.
342 MADISON AVENUE
NEW YORK 17, N. Y.

Vol. 10 No. 4

APRIL, 1949

Editorial	2
Field Findings	4
Trade Flashes	10
New TV Test Equipment, Part I, by Allan Lytell.....	15
Beginning a series of timely articles on this important subject.	
Signal Generator Design, by Douglas H. Carpenter.....	17
Modern signal generator design trends.	
Feedback & Phase Inversion, Part 2, by C. A. Tuthill	19
Concluding installment in this series.	
Custom Building for High Fidelity, Part I, by David T. Armstrong.....	21
Valuable information for the serviceman on this important source of income.	
Miniature Tube Charts.....	22, 24, 26
An excellent chart compiled by Hytron	
Circuit Court	25
Pilot Model T-741, Westinghouse Model H-169, Meck CX 500.	
Test Equipment Charts.....	28, 30
Frequency & Wave Meters, TV Calibrator, Resistance-Capacitance Bridges, Audio Oscillators, Signal Tracers.	
New Products	29

SANFORD L. CAHN
National Advertising Sales Manager

HARRY N. REIZES
Advertising Manager

JEAN M. WHEELER, Circulation Manager

DAVID SALTMAN, Production Manager

BRANCH: J. C. GALLOWAY 816 W. 5th St., Los Angeles 13, Calif., Mutual 8335

RADIO SERVICE DEALER is published monthly by Cowan Publishing Corp., 342 Madison Ave., N. Y. 17, N.Y. Subscription price: \$2 per year in the United States, U.S. Possessions & Canada; elsewhere \$3. Single copies: 25c. Entered as second class matter Dec. 13, 1948 at the Post Office at New York, N.Y. under the Act of Mar. 3, 1879. Copyright 1949 by Cowan Pub. Corp.

SOLUTION TO THE TV LEAD-IN PROBLEM!

Federal's
**Shielded Balanced
300-Ohm Lead-in Cable**



INTELIN K-111

**Minimizes Noise, "Snow" and "Ghosts"
Due to Transmission Line Pick-Up!**

**A MAJOR ADVANCE IN
TELEVISION TECHNIQUE**

**Developed by FEDERAL
Offered Only by FEDERAL
Patent Pending**

AVAILABLE IMMEDIATELY

Here is the development for which the industry has been waiting.

It is a *shielded*, balanced 300-ohm line—Intelin K-111—developed and produced by Federal—and only by Federal.

Tests have given positive proof that Intelin K-111 goes far toward solving the lead-in problem that has been a major obstacle to television progress. K-111 protects against transmission line pick-up of ignition, streetcars, fluorescent lights, diathermy and practically every other type of noise, "snow" and "ghosts" which interfere with picture clarity. This new lead-in won't pick up re-radiation from nearby lead-ins in urban areas. In rural areas, where signal strength is weak, Intelin K-111 provides greatly improved reception by reducing the noise level.

Now manufacturers can obtain a lead-in that *protects* the quality performance they build into receivers of 300-ohm input impedance. Antenna kit makers can greatly improve their products. And, by changing to Intelin K-111, servicemen can call a halt to many of the customer complaints that take the profit out of service policies.

Intelin K-111 is also recommended for a pick-up-free connection between antenna post and input stage of FM and TV receivers—and for test equipment and other HF applications. For information, write to Department D-185.

Federal Telephone and Radio Corporation

SELENIUM and INTELIN DIVISION, 900 Passaic Ave., East Newark, New Jersey

In Canada: Federal Electric Manufacturing Company, Ltd., Montreal, P. Q.
Export Distributors: International Standard Electric Corp. 67 Broad St., N. Y.



KEEPING FEDERAL YEARS AHEAD... is IT&T's world-wide research and engineering organization, of which the Federal Telecommunication Laboratories, Nutley, N. J., is a unit.

Field Findings

A resume of Industry happenings here, there and everywhere

IN June, 1948, the Federation of Radio Servicemen's Associations of Pennsylvania discussed with several radio manufacturers the possibility of conducting a statewide "Preventive Radio Month" campaign. It was decided that such a plan was feasible and practical. However, instead of attempting such a campaign for the entire State, and to learn what faults and pitfalls should be avoided, it was proposed that a single chapter and a single city in Pennsylvania be selected to act as proving ground for future activities.

Accordingly, the Mid-State Radio Servicemen's Association of Harrisburg, Pa., held a "Preventive Maintenance Month", all of November,

by **S. R. COWAN**

1948. Although hampered by lack of time for long-range planning, the campaign was put into effect by the coordinated efforts of the Harrisburg Chapter members; their local parts jobbers and such manufacturers as Philco, Sprague and Raytheon; the local newspapers and broadcast stations, both FM and AM.

The Pennsylvania State Federation's secretary assembled, with the help of the co-sponsors, a series of window displays, streamers, blotters and divers publicity material. Examples of these are shown on this page. In addition, Mid-State's radio

service dealers were supplied with co-operative advertising funds by the jobbers for both newspaper, direct mail and radio advertising. The local broadcast stations made frequent spot announcements to the public advising of the necessity for periodic checkups of their radios.

As a result of having the set-owning public continuously bombarded by radio and other types of advertising about "Preventive Radio Month", the campaign was a tremendous success for all parties concerned. For example, of the Mid-State Chapter members who participated in the venture, 70% reported increases in service work business of from 25% to 30% for the month of November 1948 as compared with November 1947, despite the fact that November 1947 was rated as having been one of the best months in the history of the profession.

The participating Mid-State mem-

bers reported that 65% of the repair jobs were on prewar type sets, 30% on postwar made sets, and 5% applied to industrial, record-changer or p-a applications. The non-participating Mid-State members, (for not all were inclined to go along with the idea, believing it might cost more than it was worth, or else being employed servicemen could not participate directly), reported their business increased approximately 15% over November 1947.

Co-operative newspaper display advertisements like this appeared regularly. In each one the names of participants appeared, but their positions were changed so that no firm got a better break than a competitor. Also, Mid-State's "Code of Ethics" got plenty of publicity, increasing prestige for its members.

Breakdown on Purchases

Analyzing the replacement purchases required by the "Preventive Maintenance Month", it was found that, as compared to 1947 business during the month of November, in

WINTER is the season of seasons... this glorious time of inner warmth... this joyous planning for others' joy... this glow that grows from giving... this proof of our finer selves... this beloved source of happiness... this magic... this wonder... **... this is Christmas**

Mid-State Radio Servicemen's Association of Pennsylvania

Wm. R. McGURDY 738 E. 10th St. Phone 6-3147	JOE COOPER 1718 Spruce St. Phone 6-3190	WAYNE E. NITE 422 E. 15th St. Phone 7-2318	FRED W. BROWN New Cumberland R. D. 1 Phone 6-1176
MEGONNELL'S RADIO Parkside Phone 5-4633	COLONIAL PARK RADIO Finkle & Oak Park Rd. Phone 5-5020	GEO. E. HARDY 1519 N. Fourth St. Phone 2-0193	BEACHLEY RADIO 1519 N. Fourth St. Phone 1-8790
HILL'S RADIO 1411 Susquehanna St. Phone 3-8342	T. L. CLARKSON 258 North St. Phone 2-3557	PAUL W. SMITH 326 East 11th St. Phone 4-1178	L. B. SMITH 7 W. Berry St., Seaside Phone 7-75-2
KLINGE'S RADIO 1418 E. 10th St. Phone 2-1895	RUSSELL'S RADIO 239 Lincoln St., Seaside Phone 7-4237	GEO. WACHTMAN 3658 Brohan St. Phone 4-1924	
JUNGMAN ELECTRONICS 2320 E. 7th St. Phone 7-8232			

FOR RADIO PREVENTIVE MAINTENANCE

See One of the Following Members

MID-STATE RADIO SERVICEMEN'S ASSOCIATION

CODE OF ETHICS
MID-STATE RADIO SERVICEMEN'S ASSOCIATION of Pennsylvania

- To do the best possible work for every customer.
- To be honest and straightforward.
- To use whatever practicable, original factory replacement parts.
- To use only standard parts equal or superior in quality to the parts replaced.
- To exercise special care in handling a customer's property.
- To charge a fair and just price.
- To estimate parts and work for ninety days.
- To refrain from unfair and unethical practices, including no unrestricted advertising, unreasonable promises or statements, refusal or undue criticism of other servicemen, or any conduct that might lead to loss of confidence in the M.S.R.S.A., or to a loss of any of its members.
- Members are required to furnish itemized bill with each service job.

KLINGE'S RADIO 1418 E. 10th St. Phone 2-1895	JUNGMAN ELECTRONICS 2320 E. 7th St. Phone 7-8232	JAY'S ELECTRONICS 1434 Berry St. Phone 6-2525	WAYNE E. NITE 422 E. 15th St. Phone 7-2318
GEO. E. HARDY 1519 N. Fourth St. Phone 2-0193	Wm. R. McGURDY 738 E. 10th St. Phone 6-3147	MEGONNELL'S RADIO Parkside Phone 5-4633	SCHMIDT'S ELECTRICAL 22 E. Third St., Seaside Phone 7-8145
RUSSELL'S RADIO 239 Lincoln St., Seaside Phone 7-4237	GEO. WACHTMAN 3658 Brohan St. Phone 4-1924	HILL'S RADIO 1411 Susquehanna St. Phone 3-8342	MEGONNELL'S RADIO Parkside Phone 5-4633

CODE OF ETHICS
MID-STATE RADIO SERVICEMEN'S ASSOCIATION of Pennsylvania

- To do the best possible work for every customer.
- To be honest and straightforward.
- To use whatever practicable, original factory replacement parts.
- To use only standard parts equal or superior in quality to the parts replaced.
- To exercise special care in handling a customer's property.
- To charge a fair and just price.
- To estimate parts and work for ninety days.
- To refrain from unfair and unethical practices, including no unrestricted advertising, unreasonable promises or statements, refusal or undue criticism of other servicemen, or any conduct that might lead to loss of confidence in the M.S.R.S.A., or to a loss of any of its members.
- Members are required to furnish itemized bill with each service job.

Approved by York Radio & Radio

CODE OF ETHICS
MID-STATE RADIO SERVICEMEN'S ASSOCIATION of Pennsylvania

- To do the best possible work for every customer.
- To be honest and straightforward.
- To use whatever practicable, original factory replacement parts.
- To use only standard parts equal or superior in quality to the parts replaced.
- To exercise special care in handling a customer's property.
- To charge a fair and just price.
- To estimate parts and work for ninety days.
- To refrain from unfair and unethical practices, including no unrestricted advertising, unreasonable promises or statements, refusal or undue criticism of other servicemen, or any conduct that might lead to loss of confidence in the M.S.R.S.A., or to a loss of any of its members.
- Members are required to furnish itemized bill with each service job.

JOE COOPER
1718 Spruce St.
Phone 6-3190

COLONIAL PARK RADIO
Finkle & Oak Park Rd.
Phone 5-5020

T. L. CLARKSON
258 North St.
Phone 2-3557

FRED W. BROWN
New Cumberland R. D. 1
Phone 6-1176

BEACHLEY RADIO
1519 N. Fourth St.
Phone 1-8790

L. B. SMITH
7 W. Berry St., Seaside
Phone 7-75-2



RADIO AND TELEVISION TUBES

**"THEY SELL FAST
AND STAY SOLD!"**

YOU have the word of other experienced servicemen for it—Ken-Rad tubes are a fast-turnover line. And they give satisfaction. They make friends for your shop.

By word-of-mouth endorsement alone, Ken-Rad tubes will gain a good name in any locality. They're a quality product, a better tube . . . and such news gets around!

But there's a faster way to bring Ken-Rad dependability to the notice of your customers. *Advertise!* Ken-Rad makes it easy for you. See the counter displays shown on this page.

In a jiffy you can put one, or both, of these attention-getters where people coming into your store are sure to see them. Also, the Ken-Rad wall plaque, decal, and giant tube carton will help identify your premises. There are blotters, postcards, stationery, repair stickers—many other aids to sales that up-and-coming servicemen have found effective. Ken-Rad's new shop coats and uniforms already are a smash hit!

Phone or write your nearby Ken-Rad distributor. He will be glad to show you how Ken-Rad radio-TV tubes—a profitable line—*can be made more so* by taking full advantage of Ken-Rad's streamlined promotion helps!



KEN-RAD *Radio Tubes*
PRODUCT OF GENERAL ELECTRIC COMPANY
Schenectady 5, New York

say servicemen everywhere.



KEN-RAD'S LIVE LINE OF PROMOTION PIECES HELPS TO KEEP SALES HIGH. YOUR CASH REGISTER WILL CHIME APPROVAL OF THESE NEW HIGH-OCTANE COUNTER CARDS.



In full colors, varnished for extra brilliancy, the cards have a fast getaway that draws the customer's eye. Also, they feature the service you sell, not just the tubes! Supplied with built-in folding easel mounts.

ASK YOUR KEN-RAD DISTRIBUTOR TO DESCRIBE THE MANY OTHER SALES AIDS AVAILABLE!

The Serviceman's Tube

When Your Radio Needs Attention . . .
Member of Mid-State Radio Service Men's Association
Please call us for
GUARANTEED RADIO SERVICE
ANY MAKE OR MODEL

FACTORY TRAINED EXPERTS
APPROVED STANDARD PRICES

PHILCO SERVICE

T. L. CLARKSON
"Your Radio Doctor"
Phone 2-9557
258 North St. Harrisburg, Pa.

Member of Mid-State Radio Service Men's Association
Yes, I am looking for reliable radio service. Please contact me as soon as possible.

Name _____
Address _____
Telephone _____
Make of Radio _____ Model _____

Don't let noisy
RADIO RECEPTION
MAR YOUR ENJOYMENT
OF
Today's Fine
RADIO PROGRAMS
GET THIS
NOT THIS

Manufacturers furnished thousands of postcards, each containing the message that it came from a member of the Mid-State Radio Servicemen's Association.

1948 Service Dealers reported that 15% of the Mid-State members sold 35% more tubes, 15% more condensers and 12% more controls; 30% of the Association members sold 25% more tubes, 10% more condensers and 10% more controls; 60% of the Mid-Staters sold 20% more tubes, 10% more condensers and 5% more controls. (Editor's note to RMA:—here's proof positive that Service Dealers can and will sell more of your products in the replacement field if given a little support in educating the set-owning public).

That the general public was more than satisfied with "Preventive Maintenance Month" is attested by the gratifying number of letters which said, in effect: "I was glad to know there is such a thing as an Association of reliable radio servicemen"—"I didn't even think about having my small set repaired until I started reading those advertisements because I got so used to using my big radio set"—"I thought my set couldn't be fixed until those servicemen's advertisements made me take a chance on it".

The Campaign Was Successful

Yes, during Harrisburg's "Preventive Maintenance Month" it was a common thing to see people bringing into service shops their own, or their neighbors' sets. Most of those repair jobs were sets that had long lain in disuse either because the owner was wary of trusting radio servicemen or merely because of habit to put off calling the radio repairman until all

the sets in the house had gone bad. The majority of Mid-State members also reported that having been called to a home to "look over a set" they found the customer frequently had two or three other radios that they also wanted to have checked "as long as you're here to do 'em."

Summarized, Harrisburg, Pa. and its guinea pig test case of trying a "Preventive Maintenance Month" was a success from every angle. The broadcast stations learned they had helped put more sets into operation, thereby increasing their listening audience, (which allows them to increase rates for commercial sponsors); the Parts Jobbers more than offset their cash outlay in cooperative advertising by obtaining a vastly increased number of replacement parts, tubes and instruments sales; the members of Mid-State Chapter had a booming profitable and busy month; the set-owning public learned to respect their local radio Service Dealers and Technicians for integrity and efficiency, and more pleasurable radio listening; the radio dealers and service organizations who were not members of the Mid-State Chapter appreciated what benefits accrue to members of such a local organization even though they got a share of the increased repair traffic merely by default; and finally, the membership of Mid-State Chapter learned that only because it was affiliated with a State Federation that

had the strength and recognition to launch the "Preventive Maintenance Month", using them as guinea pigs, was the project carried to a successful conclusion. Now, the Pennsylvania State Federation is laying the groundwork for its plans to have a State-wide "Preventive Maintenance Month" in 1949.

This is fine, in-so-far as Pennsylvania is concerned. But, what about the thousands of Service Dealers throughout the rest of the United States? Yours truly has long advocated such a nationwide "service month" plan. That RMA and NAB, (National Association of Broadcasters), have long sponsored such drives as "A Radio In Every Home" weeks in various parts of the country is a known fact. The RMA glowing reports on how successful such campaigns are leads one to believe that a campaign for a week or month of checkups and servicing would be just as successful, and probably more beneficial to the general public; which right now seems reluctant to buy radios unless they are TV models or battery portable types. Broadcasters are keenly aware of the fact that in TV areas conventional AM listening audiences are dropping off while TV is riding a crest of a wave, with this being only the beginning, for TV is only in its veriest infancy. So—what about it RMA and NAB! What about the idea of sponsoring a nationwide

**FOR RADIO
PREVENTIVE MAINTENANCE
MONTH**

Don't neglect small symptoms in your radio . . . serious trouble can develop. A timely call to an expert radio technician will save you money in the long run.

WILLIAM H. DePEAU
WHOLESALE DISTRIBUTOR—ILLINOIS CONDENSER
"TIME TESTED QUALITY"
1135 North 15th St.

**FOR RADIO
PREVENTIVE MAINTENANCE
MONTH**

If your radio needs service call your radio maintenance man

We recommend PHILCO
Quality Parts & Tubes & Batteries

JOHN A. BLESSING
Distributor
48 S. Cameron St.

**RADIO
PREVENTIVE MAINTENANCE
MONTH**

If you need service contact
Your Radio Technician

D & H DISTRIBUTING CO.
311 S. Cameron Street
Distributor of First Line Quality R. C. A. Parts

**FOR RADIO
PREVENTIVE MAINTENANCE
MONTH**

Contact your local Radio
Technician for Service

"The Home of Electronic Parts for Servicemen"

Radio Distributing Co.
140 S. Second Street Harrisburg
WHOLESALE ONLY

**FOR RADIO
PREVENTIVE MAINTENANCE
MONTH**

Wise folks don't wait until they are flat on their backs to see a doctor . . . show the same wisdom with your radio . . . call your radio maintenance man.

USE GENUINE ZENITH PARTS
FOR DEPENDABLE ZENITH MAINTENANCE

CHARLES G. KNERR
Zenith Distributor
317 S. Cameron Street

Jobbers and Distributors ran regular newspaper schedules, their advertising spaced several days apart, each advertisement stressing "Radio Preventive Month", and the need for periodic radio set checkups.

Test Pointers

ON DC VOLTAGE MEASUREMENTS

DC voltage can be measured in high-resistance circuits provided the measuring instrument does not load the circuit appreciably. A satisfactory instrument must have an input resistance which is high compared to the resistance of the voltage source.

The necessity for using a high-resistance instrument will appear from analysis of the circuit shown in Fig. 1. It is seen that the current drawn by voltmeter V across terminals A and B flows through the 1-megohm resistor. This meter current produces an IR drop across the resistor which causes the voltmeter to read less than the 3-volts of the source.

When measurement is attempted in this case with a 1000-ohms-per-volt meter (3000 ohms on the 3-volt range), meter V will read 0.01 volt instead of 3 volts. When measurement is made with a 20000 ohms-per-volt instrument (60000 ohms on the 3-volt range), meter V will read approximately 0.171 volt. Obviously, neither instrument would be suitable for the application.

However, if meter V has a very high resistance of, say, 10 megohms the reading will be 2.75 volts. The error involved is approximately 8 per cent, which is not excessive in most electronic service work. Measurements of this type are encountered in avc, bias-cell, and various "zero-bias" grid circuits.

Many dc voltages exist only during the time that the circuits carry high-frequency ac, a condition which imposes further requirements upon dc voltmeters. For example, local oscillators, multivibrators, and afc circuits develop dc bias potentials only when ac is present. If the bias is measured at the grid of a local oscillator with a high-resistance voltmeter and direct probe, the reading is usually seriously in error unless special precautions are taken.

The reason is that direct probes have high input capacitance which loads high-frequency ac circuits excessively. Accordingly, dc voltmeters used in electronic service work must contain an isolating resistor in the probe to minimize this high input capacitance. This isolating resistor places a high resistance between the source voltages and the stray capacitance of the test cable. It is found in practice that a 1-megohm isolating resistor is satisfactory.

An electronic voltmeter affords the most practical means of obtaining high input resistance at low input voltages. The grid circuit of its electron tube need consume practically no current to control a large current in the plate measuring circuit. The input resistance of typical vacuum-tube voltmeters ranges from 10 megohms to 50 megohms. A value of 10 or 11 megohms is found very suitable for service work.

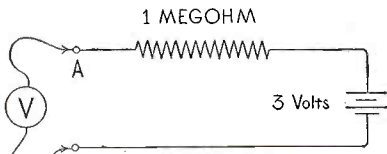
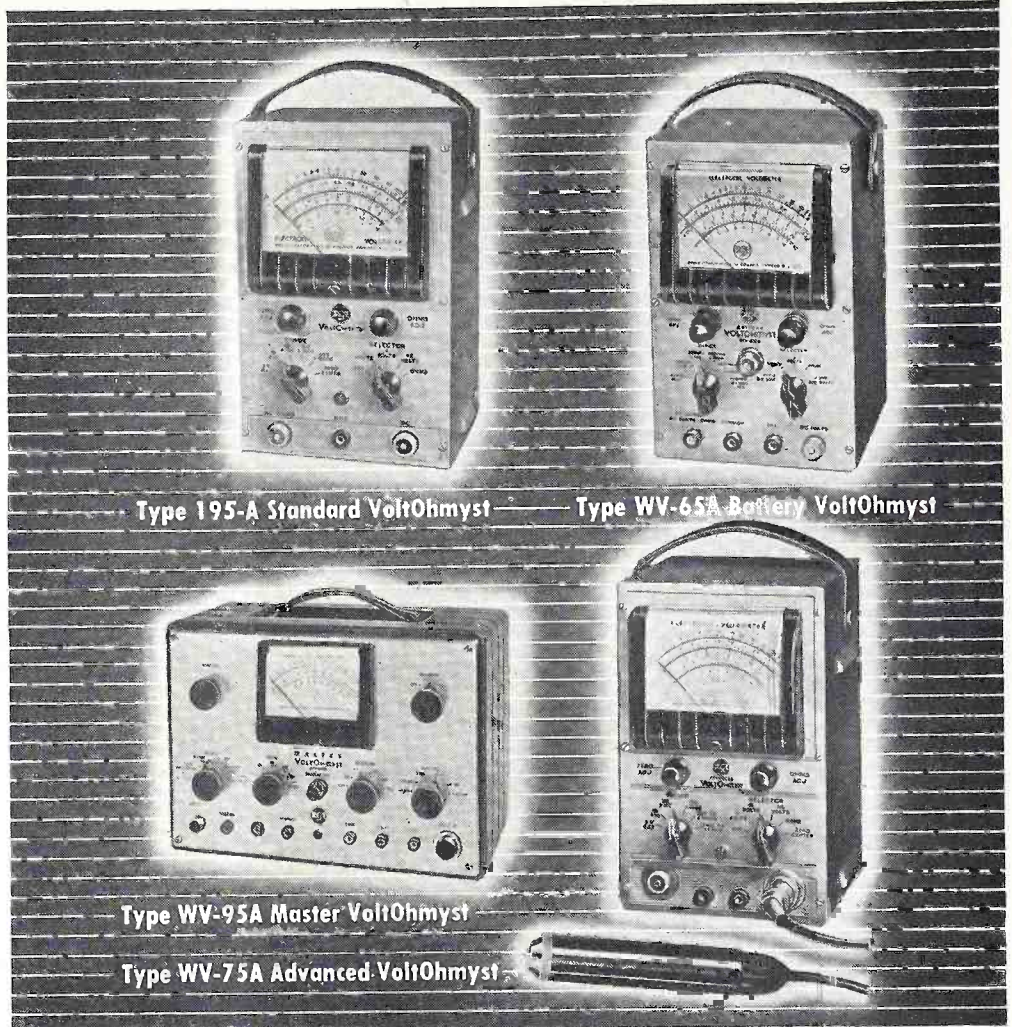

Fig. 1

Electronic voltmeters have further advantage under service conditions because the meter movement is automatically protected against burn-out from overload. The electron tubes in the instrument saturate when excessive input voltage is applied, thus limiting the current through the meter movement.

Radio technicians find little need to measure dc voltages in excess of 1000 volts. However, television technicians who wish to multiply the upper limit of their instruments to 10 kilovolts, or more, can do it by the use of a specially designed high-voltage probe.

The input resistance of such probes is very high. For example, a typical 30-kilovolt probe for use with an electronic voltmeter having 11 megohms input resistance (10 megohms input resistance without the dc probe), utilizes a 1090-megohm resistor in the high-voltage probe tip. Accordingly, the total input resistance to the instrument becomes 1100 megohms. With such a probe, the voltage scale reading should be multiplied by 100.



ONLY RCA MAKES THE VOLTOHMYST*

For high input resistance . . . accurate readings despite line voltage changes . . . full overload meter protection . . . stability under all conditions of operation . . . buy an RCA VoltOhmyst!

Type 195-A Standard VoltOhmyst: The "work horse" of electronic meters. Measures ac and dc voltages to 1000 volts, resistance to 1000 megohms, and direct current to 10 amps. WG-263 accessory Crystal Probe permits ac voltage measurements to 100 Mc. Has zero-center scale for discriminator alignment. 10-megohm dc input resistance insures good accuracy.

Type WV-95A Master VoltOhmyst: Truly the "master" electronic multimeter, this versatile instrument measures ac and dc voltages to 1000 volts, dc current from 1 microamp. to 10 amps., resistance from 0.1 ohm to 1000 megohms, and capacitance from 4 $\mu\text{p.f.}$ to 1000 $\mu\text{f.}$ Pointer may be zero-centered for discriminator alignment. WG-275 Diode Probe accessory available to extend ac voltage measurements to 250 Mc.

Type WV-65A Battery VoltOhmyst: The completely portable instrument that

works anywhere. Batteries last up to 10 months. Measures ac and dc voltages to 1000 volts, resistance to 1000 megohms, and direct current to 10 amps. WG-263 accessory Crystal Probe permits ac voltage measurements to 100 Mc.

Type WV-75A Advanced VoltOhmyst: A versatile instrument for TV and HF measurements. Reads flat to 250 Mc. Measures peak-to-peak voltages. Measures ac and dc voltages to 1000 volts, resistance to 1000 megohms. Complete with diode probe.

Ask about the new High-Voltage Probes WG-284 and WG-288 to extend the dc voltage range of these instruments to 30,000 volts.

Get further details on the RCA VoltOhmyst of your choice from your RCA Distributor, or write RCA, Commercial Engineering, Section 55 DX, Harrison, New Jersey.

*Trade Mark "VoltOhmyst" Reg. U. S. Pat. Office

Always keep in touch with your RCA Distributor



RADIO CORPORATION of AMERICA
TEST AND MEASURING EQUIPMENT HARRISON, N. J.

LP FLASH!

Alliance Announces . . .

TWO New Record Players!

Why worry about which speed?
End your L-P problems with
these two Alliance **FIRSTS!**

NEW —

Dual-Speed 33 1/3 and 45 r.p.m. Record Player (Model J.P.D.) combines both new slower speeds in one single player unit, complete with motor and turntable. Ideal as a single player; it can also be adapted to record changers!

NEW —

Single-play 45 r.p.m. record player (Model J.P. 45) expressly for the new 45 r.p.m. records . . . a complete motor and turntable assembly.

Starting on March 1st, Alliance announces mass production on both new models! Like all other Alliance Phonomotors, they are built and engineered for long life and trouble-free operation.

Service Repair Shops, Retail Service Dealers and Retailers

can order the new Alliance LP players from their regular jobber. Both players come individually boxed — make ideal units for conversion work and for resale to customers.

Meet the rapidly growing demand caused by the popular trend to the new record speeds by ordering Alliance players from your jobber—NOW!

alliance motors

Alliance Manufacturing Company • Alliance, Ohio
Export Department: 401 Broadway, New York, N.Y., U.S.A.

“Preventive Maintenance” week or month? It would bring the radio servicing profession a lot more business, and prove to be a greater benefit to the set-owning public than any other idea that we’ve heard about.

REGULARLY SCHEDULED

BROADCASTS

DURING RADIO PREVENTIVE
MAINTENANCE MONTH

NOVEMBER 1948

Radio Station WHP 1460 KC 1000 Watts

WHP SCHEDULE

Monday	11:30 P.M.
Tuesday	8:45 A.M.
Friday	9:15 A.M.
Saturday	8:45 A.M.
	2:05 P.M.
	4:30 P.M.
Sunday	9:15 A.M.
	11:30 P.M.

* * *

Four other stations in the area cooperated with spot announcements at various times that their operating schedules would permit.

Stations, both AM and FM in nearby cities (up to 26 miles away) asked to be allowed to participate in these broadcasts, but due to lack of sufficient personnel to put on these programs, the efforts were concentrated in the immediate area.

RMA’s membership is made up of radio set manufacturers and the parts manufacturers who supply them with their components. Naturally RMA’s biggest income is derived from its group of set-manufacturer members. Naturally this group, being new set sales-minded, has the biggest say in how RMA funds are to be expended, and they see to it that the “Radio In Every Home” drives are well financed. On the other hand, the parts manufacturers who belong to RMA, and who sell their output to the set makers, do not want to jeopardize their customers’, (the set maker’s), good will by asking RMA to devote a share of its money to the support of repair and replacement business, which in effect can be considered to be competitive to new set sales. So, it is incumbent upon those of us who are

[Continued on page 35]

Service Dealers

Form A Group,

Subscribe to "RSD"—

SAVE Up to \$1.00 each.

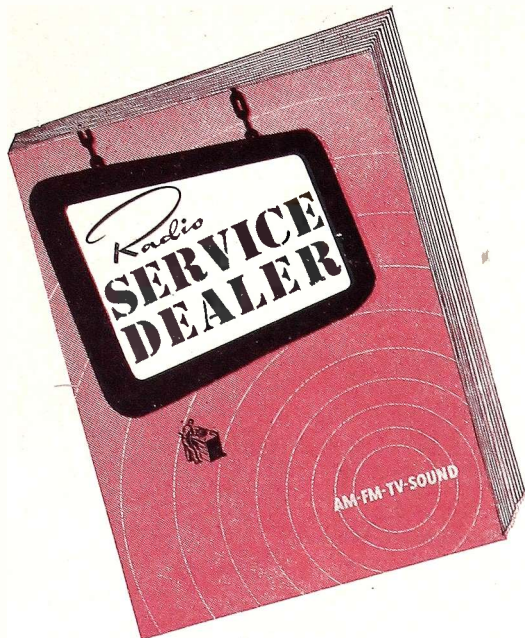

"The Professional Radioman's Magazine"—published monthly. All articles are exclusive and timely. Practically every issue is worth what an entire 1 year subscription costs.

★ The more in a group the bigger the savings. 6 men in a group save \$1.00 each; 4 men groups save \$.75 per man. Present "RSD" subscribers may participate in or form a group with co-workers, or even competitors. Still active subscriptions are automatically extended 1 year. Start a Group today! The timely and exclusive technical data appearing in future issues of "RSD" will make this the best investment you ever made. The special Group Rate offer may be withdrawn at any time—so hurry.

Use This Coupon For Convenience

(The coupon below can be used for from 1 to 6 subscription orders. Use it today!)



RADIO SERVICE-DEALER MAGAZINE
342 Madison Ave., New York 17, N. Y.

Please enter 1 year subscription orders for the names given below. Our remittance is enclosed.

NOTE: If you do not wish to tear this order blank out, just print or type the information on a single sheet of paper, following the style given. Each subscriber's occupation must be clearly described.

Name.....
Address.....
Describe Title or Position and Type of Business.....
State whether a New Subscriber or Renewal Order

Name.....
Address.....
Describe Title or Position and Type of Business.....
State whether a New Subscriber or Renewal Order

Name.....
Address.....
Describe Title or Position and Type of Business.....
State whether a New Subscriber or Renewal Order

	In U.S.A. & Canada	Foreign Rates
<input type="checkbox"/> One 1-year subscription	\$2.00	\$3.00
<input type="checkbox"/> Two 1-year subscriptions, each	1.75	2.75
<input type="checkbox"/> Three 1-year subscriptions, "	1.50	2.50
<input type="checkbox"/> Four 1-year subscriptions, "	1.25	2.25
<input type="checkbox"/> Five 1-year subscriptions, "	1.10	2.00
<input type="checkbox"/> Six 1-year subscriptions, "	1.00	1.50

Name.....
Address.....
Describe Title or Position and Type of Business.....
State whether a New Subscriber or Renewal Order

Name.....
Address.....
Describe Title or Position and Type of Business.....
State whether a New Subscriber or Renewal Order

Name.....
Address.....
Describe Title or Position and Type of Business.....
State whether a New Subscriber or Renewal Order

SPRAGUE PHENOLIC-MOLDED TELECAP* TUBULARS

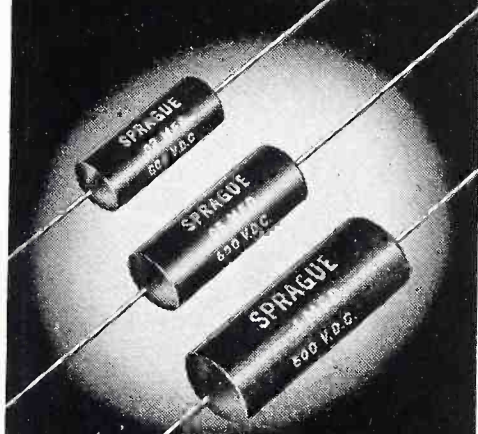

**THE MOST
TRULY
DEPENDABLE
PAPER
TUBULAR
CAPACITORS
EVER OFFERED
TO THE
SERVICE
PROFESSION**

- Extra Dependability at No Extra Cost
- Withstand Heat and Humidity, Shock and Vibration
- High Insulation Resistance
- High Dielectric Strength
- Unequaled for Sizzling AC-DC Midgets, or "Hot" TV and Auto Sets.

See Your Jobber Today!

SPRAGUE PRODUCTS CO.

North Adams, Mass.

*Trademark

TRADE FLASHES

A "press-time" digest of production, distribution & merchandising activities

The Publisher and Staff of RSD, together with his friends and associates, mourn the passing of John H. Potts, author, engineer, editor and publisher.

TV Set Shipments

Shipments of television receivers by RMA member-manufacturers increased 88 percent during the fourth quarter of 1948 over shipments in the third quarter, the Radio Manufacturers Association reported today.

At the end of the past year RMA set manufacturers had shipped 964,206 TV receivers into 42 states and the District of Columbia since January 1, 1947, when the shipment reports were started.

Fourth quarter shipments by RMA members totalled 354,314 as compared with 188,120 during the third quarter of 1948. Shipments during the entire year numbered 802,025.

TV set shipments, RMA explained, always trail behind production reports which previously had shown RMA member-companies producing 866,832 television receivers in 1948. Total industry production was estimated at more than 975,000 TV sets.

New York City area continued to lead in the number of sets shipped both for the fourth quarter and the accumulative period to date. Philadelphia rose to second place in the total number of TV receivers shipped followed closely by Newark, Los Angeles, Chicago, Washington, Boston, Baltimore and Detroit.

More than 293,000 TV sets were shipped into New York state during the two-year period and more than 109,000 were shipped into Pennsylvania.

DC TV

A ten-inch television set operating on DC only, will be introduced by Stewart-Warner in the New York market March 2. This was announced today by E. L. Taylor, general sales manager of Stewart-Warner Electric, a division of Stewart-Warner Corporation.

Toscanini Praises RCA Record

Arturo Toscanini, distinguished conductor, who recently returned to the airwaves to conduct the NBC Symphony Orchestra in a Spring series of concerts, is shown here with RCA Victor's new 45 RPM record and record player, which is soon to be shown to the public.

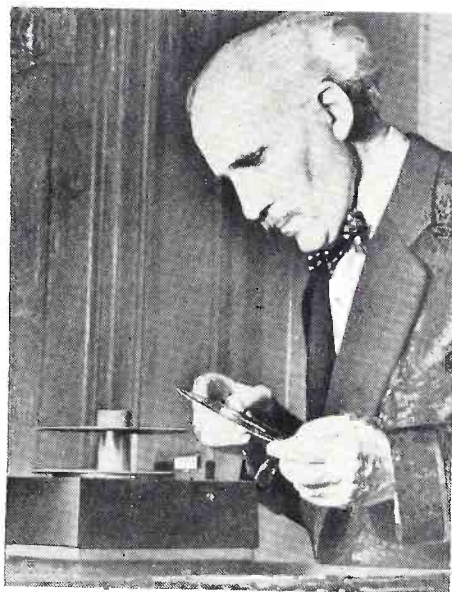

Toscanini has described the new phonograph-record system as a "remarkably faithful reproduction of recorded music" which is a "significant advance in the field of recorded music." The famous conductor is one of many distinguished musical artists who have praised the new distortion-free records, which are made of non-breakable vinyl plastic and are less than seven inches in diameter.

Astatic Ceramic Mikes

Microphones employing the new piezoelectric ceramic elements, which are unaffected by extremes of temperature or humidity, are here to stay as far as The Astatic Corporation, Conneaut, Ohio, is concerned. This pio-

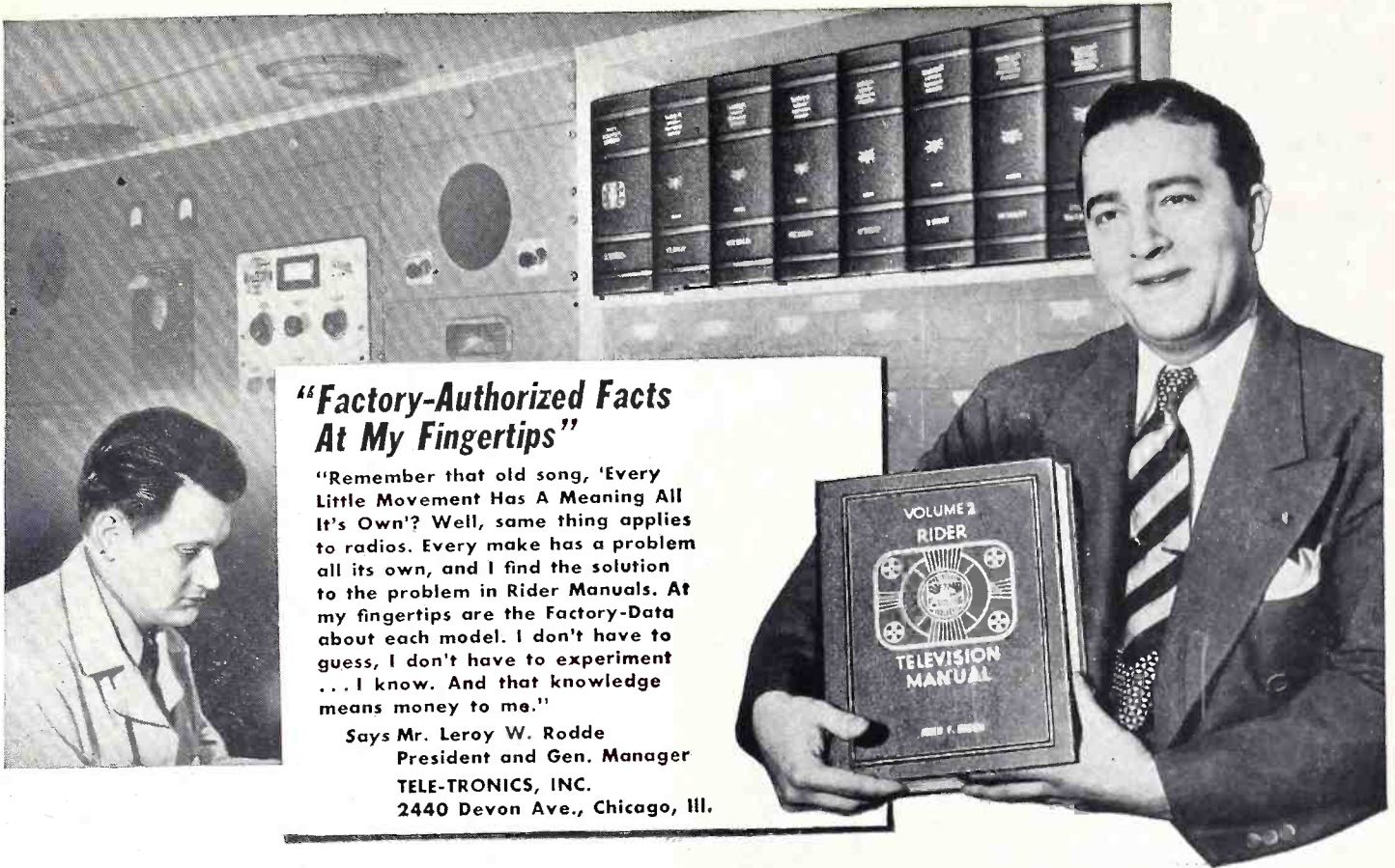

"Factory-Authorized Facts At My Fingertips"

"Remember that old song, 'Every Little Movement Has A Meaning All It's Own'? Well, same thing applies to radios. Every make has a problem all its own, and I find the solution to the problem in Rider Manuals. At my fingertips are the Factory-Data about each model. I don't have to guess, I don't have to experiment ... I know. And that knowledge means money to me."

Says Mr. Leroy W. Rodde
President and Gen. Manager
TELE-TRONICS, INC.
2440 Devon Ave., Chicago, Ill.

Only RIDER MANUALS
Supply ALL the AUTHENTIC, OFFICIAL, RELIABLE Servicing Data
Direct From the Manufacturers... AM-FM-TV — and Allied Equipment

Available Now! VOLUME 18
2036 Pages PLUS "How It Works" Book and Cumulative VOLUMES XVI, XVII, XVIII Index. Both Books, Complete..... \$19.80

Authentic factory-data covering models and chassis of AM and FM receivers and record changers of more than 100 manufacturers, up to date to January, 1949. Exclusive RIDER "Clari-Skematix" give break-downs of hard-to-trace multi-band receivers, showing circuit wiring of each band.

Now Available! RIDER TELEVISION MANUAL-VOLUME 2
2000 Pages PLUS Cumulative Index Covering TV Volumes 1 and 2 \$18.00

AUTHENTIC, OFFICIAL Service Data on Complete Receivers and Kits and Boosters direct from the service departments of 57 TV manufacturers. Double, triple spreads and giant pages that unfold to 4440 square inches. Test patterns, wave forms, schematics, voltages, adjustment of traps, complete alignment tables. Parts list.

For 18 years, RIDER MANUALS have been the ONE and ONLY dependable source of data to help servicemen solve any problem on any make or model of radio in existence. That's because RIDER MANUALS incorporate ALL and we did say ALL, the AUTHENTIC, OFFICIAL data as put out by the manufacturers themselves. For example, in TV MANUAL VOLUME 2, we show seven different chassis for the same model number. Only RIDER MANUALS offer you such scope, such a wealth of information, and in such easily-followed form.

RIDER MANUALS

Vol. XVIII	2032 Pages \$19.80	Vol. XI	1652 Pages \$16.50
Vol. XVII	1648 Pages \$16.50	Vol. X	1664 Pages \$16.50
Vol. XVI	768 Pages \$ 8.40	Vol. IX	1672 Pages \$16.50
Vol. XV	2000 Pages \$19.80	Vol. VIII	1650 Pages \$16.50
Vol. XIV	1376 Pages \$16.50	Vol. VII	1600 Pages \$16.50
Vol. XIII	1672 Pages \$16.50	Vol. VI	1240 Pages \$12.50
Vol. XII	1648 Pages \$16.50	Abridged Manual	
Rider Television Manual, Vol. 1 (Incl. HOW IT WORKS and INDEX).....	\$18.00	Vol. I-V	2000 Pages \$19.80
Rider Television Manual, Vol. 2 (Incl. HOW IT WORKS and INDEX).....	\$18.00		

RIDER PA MANUAL

The first industry-wide public address equipment Manual, covering amplifier production of 147 manufacturers from 1938 to 1948. 2024 Pages PLUS "How It Works" Book. \$18.00 Complete

Your Jobber Carries a Full Line of RIDER MANUALS
RIDER MANUALS mean SUCCESSFUL SERVICING

JOHN F. RIDER, PUBLISHER, Inc., 480 Canal St., New York 13, N. Y.

Export Agent: **Rocke International Corp., 13 East 40th Street, N. Y. C., Cables, ARLAB**

IMPORTANT NOTE! Are you receiving your copy of "Successful Servicing"? It's Rider's own publication of interest to every Serviceman. Send your name and address, and we'll put you on our list, FREE of charge.

NOTE: The Mallory Radio Service Encyclopedia, 6th edition, makes reference to only one source of radio receiver schematics—Rider Manuals.
ANOTHER NOTE: The C-D Capacitor Manual for Radio Servicing, 1948 edition No. 4, makes reference to only one source of receiver schematics—Rider Manuals.

You'll Be Proud to HAVE THIS HANDSOME OHMITE CABINET IN YOUR SHOP!



GET THIS HANDY
ALL-PLASTIC CABINET
Packed with 125 "Little Devil" Resistors
—FOR COST OF RESISTORS ALONE!

1/2-WATT ASSORTMENT
\$12.50

LITTLE DEVIL COMPOSITION RESISTORS

Guesswork's gone . . . when you use individually marked Ohmite "Little Devils." These tiny but rugged resistors are available in standard RMA values, 1/2, 1, and 2-watt sizes . . . 10 ohms to 22 megohms. Tol. $\pm 10\%$ and $\pm 5\%$. Values to 2.7 ohms available in 1-watt size, $\pm 10\%$ tol.

This lustrous, all-plastic cabinet not only adds a colorful, modern touch to your shop but saves you hours of valuable time by helping you find the resistors you need . . . fast. Factory packed in its five drawers—40 separate compartments—are 125 carefully selected Ohmite "Little Devil" Resistors in the 40 values (10 ohms to 10 megohms, 1/2-watt) most frequently used by servicemen.

Extremely compact—only 9" x 4 3/4" x 5 1/4"—this Ohmite cabinet protects your resistors, and helps you check inventory at a glance. The cabinets are dovetailed top and bottom so they can be stacked one on top of another. Order yours today!

SEE YOUR DISTRIBUTOR

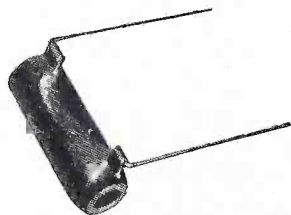

BROWN DEVIL RESISTORS

A favorite with servicemen, these dependable, wire-wound, vitreous-enameled resistors are easily mounted by their tinned wire leads. Tol. $\pm 10\%$. In 5, 10, and 20-watt sizes.

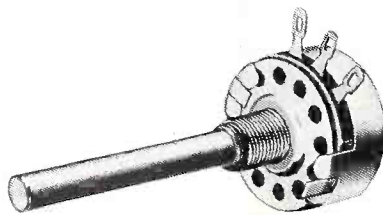

MOLDED COMPOSITION POTENTIOMETER

Built to last, this Type AB Potentiometer has a heat-treated, solid-molded resistance element—not just a film—and provides unusually quiet operation. It has a 2-watt rating.

OHMITE MANUFACTURING CO., 4846 FLOURNOY ST., CHICAGO 44

Be Right with **OHMITE**

RHEOSTATS • RESISTORS • TAP SWITCHES

ner producer of crystal microphones and phonograph pickups has announced that every crystal model As-tatic microphone, with the exception of a few special types, now is available in a look-alike ceramic model.

Operation Blackboard

"Operation Blackboard", the first major project to use television for a new kind of visual education in the classrooms of many schools simultaneously, will be launched in public, parochial and private schools in this area beginning Wednesday, March 2. Sponsored jointly by the Philadelphia Board of Education, Philco Corporation and television station WPTZ. "Operation Blackboard" consists of a series of 39 educational programs to be telecast three times a week.

GE Merchandising Display

This colorful counter display case highlights the entry of General Electric into the merchandising of phonograph "needles". The Receiver Division at Electronics Park, Syracuse, N. Y., is offering this and other sales aids to its distributors on a participation basis, as part of a plan to promote the sale of replacement styli for

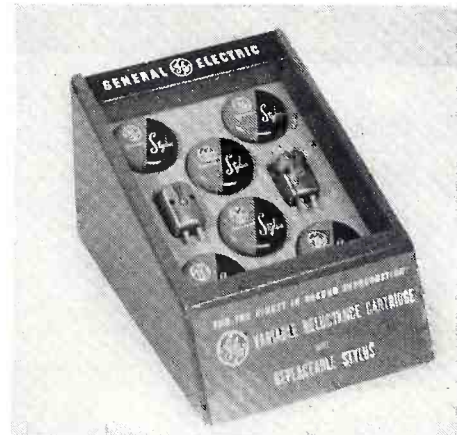

the new G-E replaceable stylus cartridge. Each stylus is sold in a small plastic case, six of which fit into the display case, along with two cartridges. Diamond styli in one, two-and-a-half, and three mil sizes have a list price of \$27.50 each. Sapphire styli in these same sizes will list for \$3.50 each.

Setchell Carlson Moves

Setchell-Carlson announces their removal to their new factory at New Brighton, Minnesota.

Pre-Recorded Wire Spools

The development and production of pre-recorded wire spools for wire recorders was announced this week by Webster-Chicago Corporation.

[Continued on page 32]

IN RADIO AND TELEVISION TUBE SALES



Electronic
TUBES

1949 IS A G-E YEAR!

A big campaign of selling aids paves your path to profits. Something new—and hot—every 60 days!



You can't beat this shop-garment offer. It proves the point when we say G-E dealer helps are "hot." You make no investment! Shirts, trousers, jackets, coats—in attractive powder blue, with the G-E pocket emblem in orange and dark blue—come to you each week freshly laundered. You rent, not buy! And the low rent is roughly equal to what you might pay for cleaning only.



Amusing—and great little business-builders! Two of the cleverest new counter cards the trade has seen! Cut-outs feature the gremlin in one case, the "sour notes" in another. They give a lifelike three-dimension effect. The cards come in full colors, varnished for brilliancy, with built-in easel mounts.

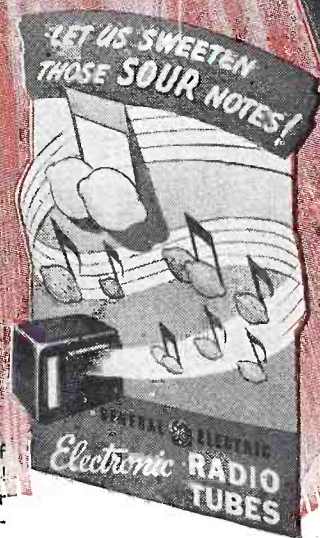

THIS is the year you'll shake hands with yourself because you're retailing G-E tubes. If you haven't any on your shelves, it will be smart to put your order in . . . fast!

G-E tubes are a fast-moving, profitable item because General Electric works with you to widen your customer list. This page shows a few of the aids-to-sales furnished you for promotion. There are plenty of others—and brand-new items will join the parade at frequent intervals.

Better tubes aren't built! G-E quality

backs up your promotion, makes friends of tube buyers. When you install a General Electric tube, you're selling others later on—to the same satisfied customer, or to persons he refers to you for tubes, parts, or radio-TV service.

Get aboard the tube-profits train! Your nearby General Electric tube distributor will be glad to show you how. Phone or write him today. Or address *Electronics Department, General Electric Company, Schenectady 5, New York.*

You can put your confidence in—

GENERAL



ELECTRIC

181-HA3-8850

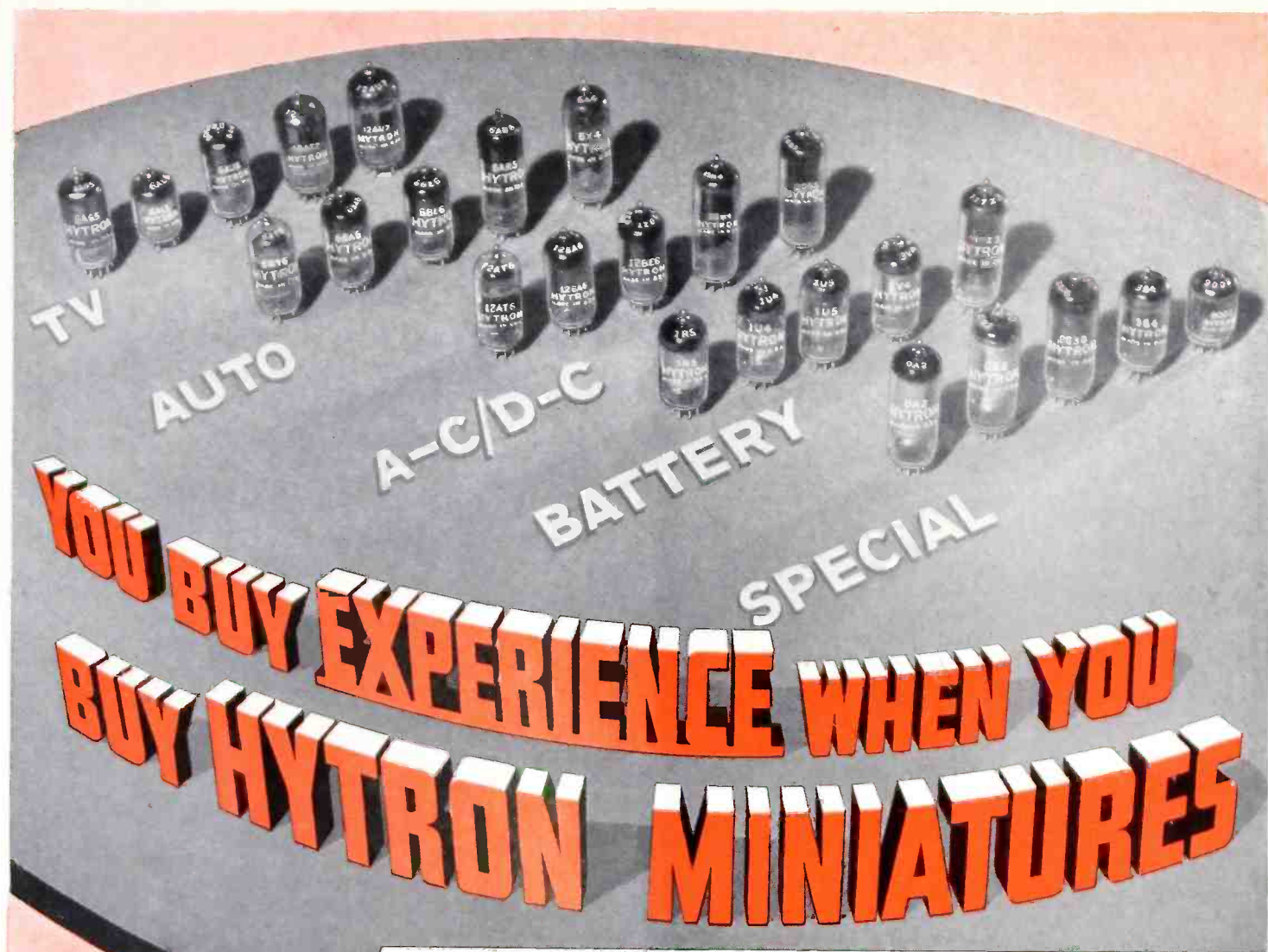

AS YOU CAN READILY IMAGINE, these little fellows are tough to make—and make right—because they are so darned tiny. A heck of a lot of *experience* is a must.

Hytron has it. First to telescope standard glass tubes to Bantam GT size. First to originate the subminiature. First to make even subminiatures tinier. First to build the smallest subminiature used in the war-time proximity fuse.

With this background in making 'em *small*, Hytron manufactured millions of wartime miniatures like the 6AK5, 9001, 9002. Quite naturally, it began to originate miniatures too. Some of the more famous: 6AR5, OB2, 2E30. Hytron also originated the first and only Reference Guide (now in its third edition) for *all* miniatures, regardless of make. Yes, when you buy Hytron miniatures, you buy the most valuable advantage any manufacturer can offer you. *Experience*.

SPECIALISTS IN RADIO RECEIVING TUBES SINCE 1921

HYTRON
RADIO AND ELECTRONICS CORP.

MAIN OFFICE: SALEM, MASSACHUSETTS



New TV TEST Equipment

by ALLAN LYTELL

PART I

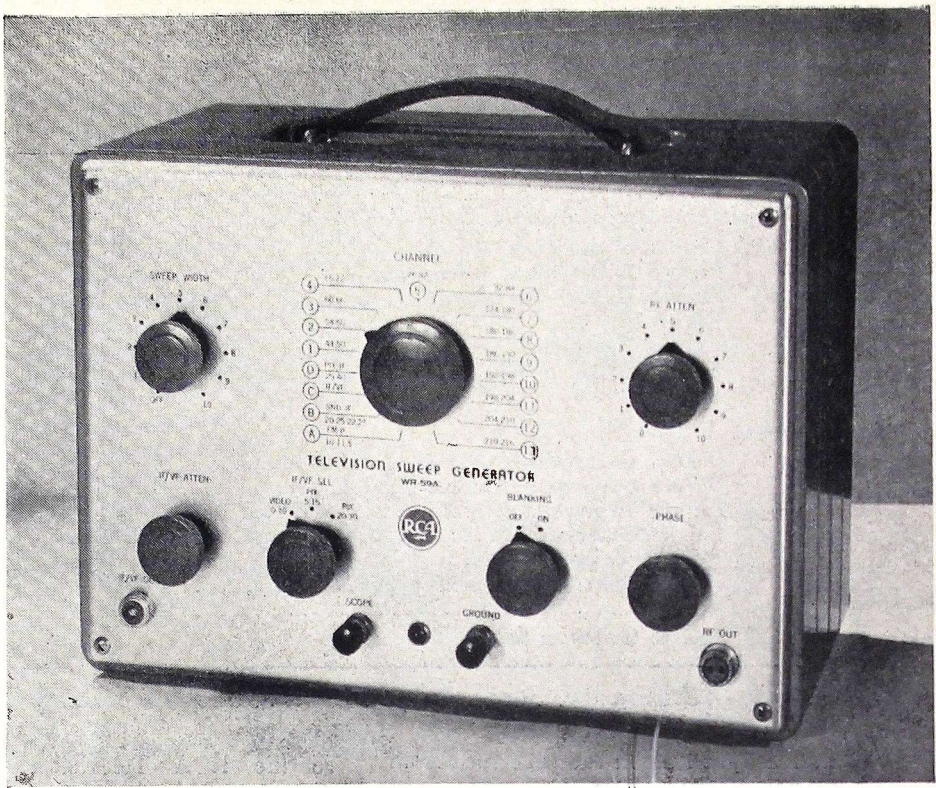

Fig. 1—The RCA WR-59A Television Sweep Frequency Generator.

A description of new Television test equipment illustrating the new features, use of controls and types of application. The equipment includes Sweep Frequency Generators, Calibrators, and special Cathode-Ray Oscilloscopes.

MANY of the larger radio repair shops are beginning to have their own television test equipment since they are doing at least some of their own repair work. Installations of television receivers may be accomplished without test equipment, but actual alignment procedures require the use of accurate and modern sweep frequency generators, calibrators, (or signal generators) and cathode ray oscilloscopes.

AM, FM & TV Requirements

The reason for the need of accurate and specialized equipment is easily seen from a brief comparison of AM, FM and Television. The alignment of an ordinary AM receiver may be accomplished with a simple generator and a good vacuum tube voltmeter. Since the AM band width is only 10 kc, very great accuracy is not necessary for the great majority of these receivers. Furthermore, while 2% of 465 kc is only 9.3 kc, 2% of 30 mc is 600 kc. Two percent of 1000 kc is 20 kc, but 2% of 215 mc is 4.3 mc. A flat-topped characteristic of an AM-IF amplifier is never obtained in actual practice. A response curve which is too sharp will detract from the signal adequacy and fidelity but this will only be noticed with the

higher priced console receivers.

In FM, with a 200-kc band width, the alignment problem becomes more acute, since any great change in this band width will not only produce distortion but will adversely affect the FM receiver in the very qualities which it is supposed to have. FM detectors are also quite critical of adjustment and need more accurate signal generators than in the case of AM. It is very important that a signal generator have precise frequency calibrations in order that the detector system, i-f system, and tuning system be tuned with the requisite degree of accuracy.

Television alignment is extremely critical as to exact frequency and band width if correct tuning and proper picture resolution are to be obtained. The sound carrier must be tuned in precisely at the right frequency, the video response band should be at least four megacycles wide, and the station calibration must be as accurate as possible, if maximum performance is to be obtained from the television receiver.

In order to accomplish these things through visual alignment, a sweep frequency generator is used, which is a type of FM signal generator. This generator produces a variable fre-

quency r-f signal which is swept across the face of the cathode ray tube. Markers, or exact points of calibration are supplied either by the sweep generator itself or by an outside source. In many cases, this outside source is a separate signal generator or frequency calibrator.

Sweep Frequency Generator

The RCA Television Sweep Frequency Generator WR-59A shown in Fig. 1, is one of the three units in RCA's package for television and FM visual alignment. This generator supplies a frequency-modulated signal covering all 12 television channels (channel 1 is no longer in use), video and sound i-f frequencies, and a special video-sweep frequency for checking video amplifiers. This unit also has the pre-war i-f picture frequencies, the i-f frequencies for FM receivers, and a spare channel. A unique feature of the frequency modulation of this device is a vibrating capacitor which provides a signal free from the undesired responses which are to be found in harmonic generators, since this r-f signal is modulated at fundamental frequencies over all ranges. One other very useful feature of this circuit is the use of a blanking circuit which establishes a zero reference sweep gener-

Characteristics

IF Center-Frequency Ranges (adjustable);

Picture Intermediate, first band.....	5-15 Mc
Picture Intermediate, second band.....	20-30 Mc
Picture Intermediate, spare*.....	25-40 Mc
FM Intermediate.....	10-11.5 Mc
TV Sound Intermediate.....	20.25-22.25 Mc
Television RF Sweeps.....	Channels 1-13
Video Sweep.....	100 kc-10 Mc

Sweep Widths:

Picture Intermediate, first band.....	10 Mc
Picture Intermediate, second band.....	10 Mc
Picture Intermediate, spare.....	6 Mc
FM Intermediate.....	1.5 Mc
TV Sound Intermediate.....	2 Mc
Television Radio (Channels 1-13).....	8 Mc
Video.....	9.9 Mc

*Set at factory to 34 Mc

Fig. 2—Tabulation of Sweep Outputs of RCA Sweep Frequency Generator.

ator output line on the tube face from which the instantaneous voltage at any point on the trace can be measured. The output of this sweep generator is flat within 1 db over all of the ranges.

The Sweep Generator is put into operation by applying a-c power and connecting the r-f and i-f cables. Sweep width is turned on which applies a-c power to the unit. The r-f output is modulated at 60 cycle frequency and the scope terminal is connected to the horizontal amplifier of the Oscilloscope.

The output center frequency is determined by the setting of the Channel Selector Switch in any of 13 positions. In position C, the IF-VF position, the IF-VF switch controls the output which is taken from the IF-VF jack. The Sweep Width control is turned to maximum and the blanking control is turned to Off. Either the IF-VF or the RF output signal is used and applied to the circuit under test. The output of the tested circuit is applied to the vertical amplifier of the scope. If two patterns are found on the scope's screen, the Phase Control should be rotated until the two patterns are superimposed. The Blanking Switch may be turned to the On position which will provide a zero base line for the response curve.

When the RF cable is in use, the IF-VF cable should be disconnected in order that there be no leakage between the two cables. Either one of the two cables may be used as an output. This Television Sweep Frequency Generator is designed to produce accurate frequency modulated signals which are used to produce a visual response curve on the screen of the test oscilloscope. A separate single frequency signal generator such

as the RCA Television Calibrator must be used to provide markers or points of exact known frequency. A tabulation of the sweep outputs of this generator is shown in Fig. 2.

TV Calibrator

The second piece of TV test equipment in the RCA package is the RCA TV Calibrator WR39A shown in Fig. 3. This calibrator unit consists of a spread-band variable-frequency oscillator, two crystal oscillators, a heterodyne detector, an audio amplifier, and miniature speaker. In general, this device uses a dual crystal oscillator which can be used directly, or to calibrate the variable frequency oscillator which produces the marker

signal. The variable frequency oscillator operates on fundamentals over its entire frequency range.

Frequency markers can be generated at any point between 19 and 110 mc and between 170 and 240 mc. External equipment can be calibrated by the zero-beat technique from 0.25 mc to 480 mc, with an accuracy of 0.01%.

The functions of the various controls as illustrated in the photograph are as follows.

1. *Tuning.* The tuning control adjusts the variable frequency oscillator to any point shown on the dial scale marking.

2. *RF Out.* In complete counter-clockwise position this control turns the variable frequency oscillator off. The voltage output of the VFO is increased as the dial is rotated clockwise.

3. *Crystal Adjust.* This tunes the 0.25 mc crystal oscillator over a small frequency band and is used to zero-beat the tenth harmonic of the .25 mc crystal oscillator to 2.5 mc \pm 0.01%.

4. *Volume.* In the completely counter-clockwise position this is the a-c on and off switch; as the control is rotated the volume of heterodyne audio output, to either phones or speaker, is increased.

5. *Calibrate.* In the crystal "off" position the crystal oscillators are not operating, but the variable frequency oscillator is operating if the RF Out control is in the "on" position. In the 2.5 mc position, the crystal oscillator

[Continued on page 46]



Fig. 3—RCA WR-39A TV Calibrator.

SIGNAL GENERATOR DESIGN

by **DOUGLAS H. CARPENTER**

THE phrase "signal generator" is one of the most misused of all technical terminology. During the early days of radio there was no equipment manufactured to test and align receiving sets. Producers of such apparatus had to design circuits to fulfill these requirements. A so-called "dynamic check" was also used. This consisted of tuning in one of the few available broadcasting stations and determining aurally if the receiver was operating properly. On good days if atmospheric conditions were favorable and good reception was had, the production run was earmarked for special friends and favorite distributors. From this crude beginning and, obviously inadequate test methods, the first test oscillator was built. It would be indeed difficult to imagine what this first unit was like. It was probably some simple oscillator circuit that could be relied upon to have a more or less constant output level, and a means devised of coupling the output to the circuit under test. The day this first instrument was employed the radio industry had made a major advance. Gradually this very essential piece of equipment was refined, and such things as output level indicators and precision attenuators were employed by manufacturers, so that a reliable and completely variable output source of frequency was available. The complicated maze of testing apparatus employed by any up-to-date electronic production line is a far cry from that utilized by early radio pioneers. Un-

Circuit analysis and description of an advanced type of modern signal generator with calibrated output meter.

fortunately the two phrases "test oscillator" and "signal generator" became so interchangeable during this period that the radio serviceman, even today, is slightly confused as to the great difference and operating merit of these two entirely different instruments. Such misunderstanding may be excused when one considers the advertising description employed by even present-day manufacturers.

Fundamentally, the test oscillator can be technically classified as any oscillating circuit that covers a required frequency range. The output may be controlled by a so-called "rough" and "fine" attenuator system. Such units are built for the purpose and intended to be used for such simple functions as aligning a broadcast or short wave set. Their applications are limited, and with the advent of FM

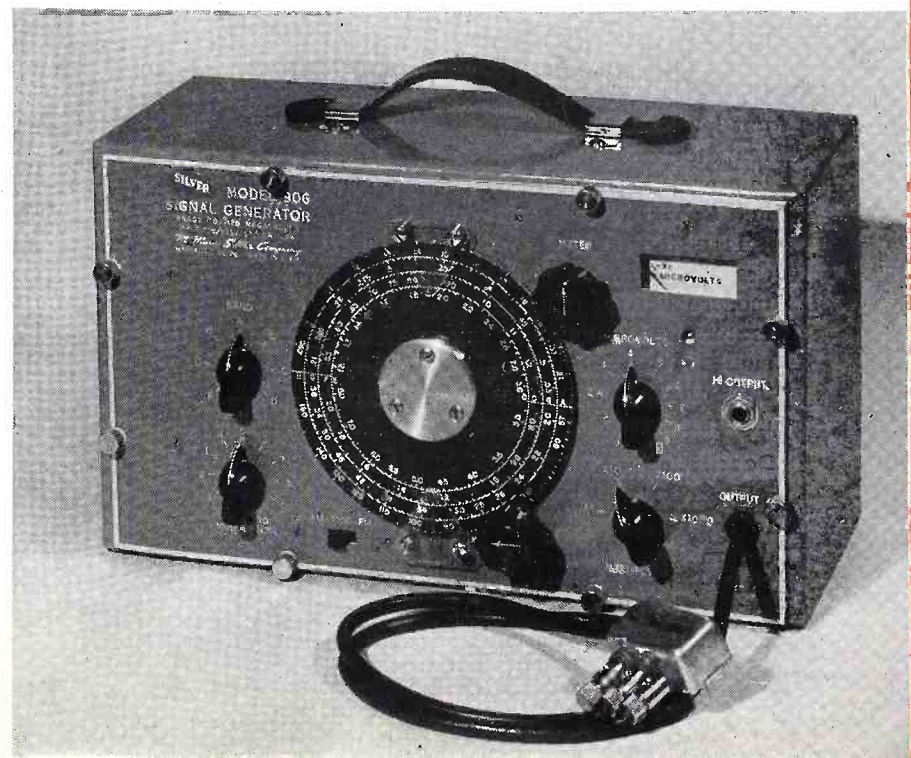

Fig. 1—McMurdo Silver Model 906 Signal Generator.

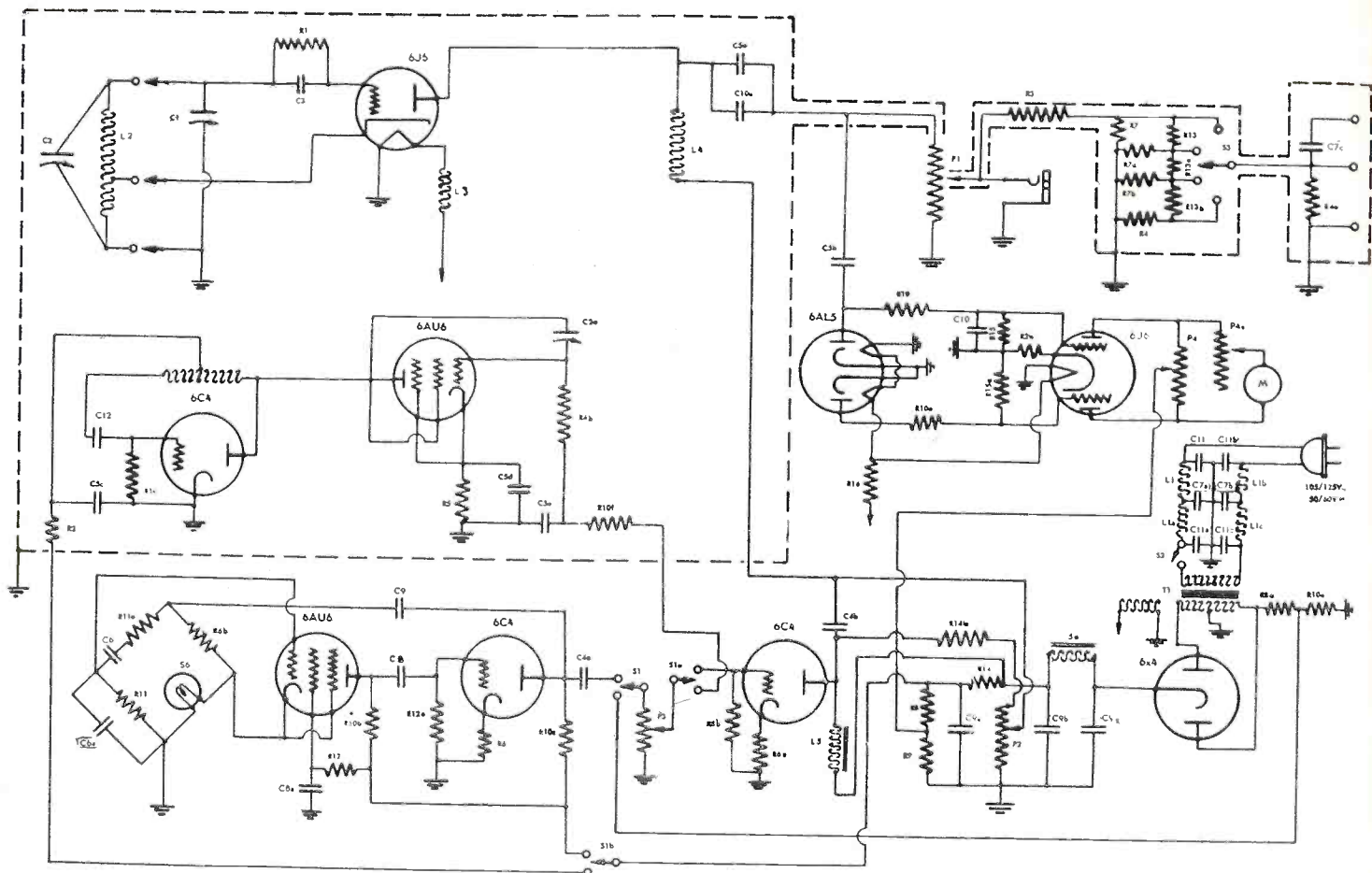

Fig. 2—Circuit diagram of McMurdo Silver Model 906 Signal Generator.

and extended frequency requirements, their functions are outdated.

A signal generator on the other hand is an entirely different type of instrument from a use standpoint. Essentially we still have an oscillating circuit, but in all cases this covers the broadcast, short wave, and FM range. Next, to meet today's requirements, a frequency modulated output is made available for visual alignment of broad band FM circuits. Finally the greatest difference and the very important thing that must be borne in mind is that a signal generator has an output level indicator and a precision attenuator so that the exact number of microvolts output may be controlled and known at all times.

It is the purpose of this article to describe completely the circuit of a modern and popular type signal generator. The generator under discussion is the McMurdo Silver Model 906, which incorporates the advanced design previously described.

Description of Model 906

Model 906 signal generator brings to the serious service technician and design laboratory, the full AM and FM frequency range. Reference to the

schematic (Fig. 1) shows that the 906 employs a Hartley oscillator circuit. The usable output from this oscillator as developed across the load circuit $P1$, through the parallel capacitor combination $C5a$, $C10a$. The output load or microvolt control potentiometer $P1$ is actually the series or oscillator return. If we trace the circuit further through $C5b$, we see that the r-f potential developed across $P1$ is in turn applied to the high impedance voltmeter circuit consisting of the 6AL5 and 6J6 tubes. The 100 microampere meter located in the plate circuit of the 6J6 has two controls. Potentiometer $P4$ controls the ratio of voltages applied to each 6J6 plate. This in turn determines the amount of bucking current in the load circuit $P4a$, M -and is used as an internal zero set control. The potentiometer $P4a$ is used as an additional internal range set to make the meter pointer agree with the meter face calibration. The meter is accurately calibrated at two points: .1 and 1 volt. The filament dropping resistor $R16$ is incorporated to nullify the effects of line voltage changes.

It is essential to keep the r-f output of the oscillator as near to sine as

possible in order to obtain true readings. If the output contained harmonic distortion to any degree the voltmeter would simply register the peak value, and in turn give false indications. This is controlled on all ranges except the highest band, where second harmonic content is purposely inserted for reasons to be explained later.

Obtaining Output in Microvolts

The voltage developed across the microvolt control $P1$ is in turn applied across the additional load circuit consisting of $R3$, $R7$, $R7a$, $R7b$, $R13$, $R13a$, $R13b$. Such voltage is in turn directly connected through switch $S3$ to the terminal box termination load $C7c$, $R4a$.

Let us consider the case of .1 volt developed across $P1$ with the center tap of $P1$ at the high end. If we compute the values of resistance in the attenuator and terminal box load we will find that this value of voltage may be divided down 5 times. The voltage appearing at the center tap of $P1$ and the high output jack is dropped 10 times before it is applied to the first step in the attenuator switch. This means if we have .1 volt

[Continued on page 42]

Feedback

&

PHASE INVERSION

by C. A. TUTHILL

PART 2

Concluding article on the subject of positive and negative feedback applications.

Negative Feedback (Current)

To this point we have been dealing with positive feedback and negative feedback of the voltage variety. A very troublesome *current* negative feedback results from a swinging plate current set up in the plate-load-cathode circuit when there is a lack of proper by-pass capacitance across the cathode resistor. (See *Fig. 6*). In power stages where the plate current is deliberately high, this type of feedback can reach such proportions as to cancel out the signal being amplified. While servicing amplifiers with single-ended (one tube) final stages, it is not unusual to reduce trouble to an open capacitor which should be shunting a cathode resistor. Ordinarily this capacitor tends to by-pass plate current variations from this grid-biasing resistor. When it fails to do so a swinging bias current is set up since the alterations in plate current then flow directly through the biasing resistor. Let us refer to *Fig. 6*. Since no capacitor is shunted across $R1$, the a-c component of plate current must flow through it. Then as the positive signal alternation (*a*) causes the grid to be less negative it creates an increase in plate current. Changes in the latter create changes in the bias voltage across the biasing resistor $R1$. When the plate current increases, an increase in bias opposes an incoming signal. When negative alternation (*b*) causes the grid to become more negative, there follows a decrease in plate current. This naturally drops the bias across $R1$ which is in series with the drop in

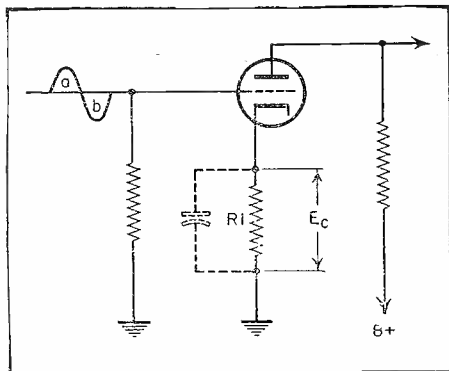

Fig. 6—Basic current feedback circuit used in many receivers and commercial amplifiers.

plate current. Well the result due to decreasing bias is also opposition to the signal on the grid. Thus we have a bias swinging first one direction then the other in direct opposition to incoming signals. This constitutes the *current* form of negative feedback the severity of which will depend upon the value of $R1$ and the magnitude of the plate current swing. As stated earlier it may become great enough to cancel out the incoming signal.

Frequency Discrimination

The magnitude of any particular frequency that will be cancelled out due to inverse feedback depends upon the content of that frequency which is present in the output of the amplifier. When an amplifier is not flat; when it exaggerates the higher frequencies, a greater proportion of those than any other frequencies will be fed back to react upon the incoming

signal. We may say that the resultant signal at any frequency, at the point of feedback, is reduced in proportion to the content of that frequency extant in the amplifier's output prior to feedback.

When the feedback is *positive* or regenerative, any non-uniformity in frequency characteristic will become exaggerated because the feedback is a percentage of the output. If the gain of an amplifier be 10 for example and 10% of the output is fed back in phase, there will be as much voltage on the input grid due to 10% feedback as there is from the original signal. When this process endures a few repetitions, each in phase with the original, the amplifier becomes overloaded and breaks into oscillation. From the above we see that any excessive gain at a particular frequency would, when fed back in phase, produce more excitation at the input than would exist for frequencies of less proportion. The characteristic for such an amplifier would get worse as regeneration continued. Uncontrolled feedback renders an amplifier *useless*.

It must be remembered that the number of components involved within the amplifier will depend upon the methods of connection. Distortion in an output transformer will, of course, not be corrected if the negative feedback connection be made ahead of it. Similarly no distortion will be corrected ahead of the point where feedback is applied. It is shown in *Fig. 7* that feedback may include several stages so that the entire amplifier may

benefit. Commercial negative feedback amplifiers today often include internal degeneration filters which may be designed to adjust the overall frequency response to meet any special requirement. High, low, or middle frequency cut-off or emphasis may thus be incorporated in stabilized degenerative amplifiers.

It is well to investigate the power rating as regards response. It is common practice for manufacturers to rate the frequency response of their amplifiers without regard to maximum power capacity. It is quite ordinary to find that the rated response can only be obtained at a power output 6 to 10 db below the maximum power rating. Reference is made here to the commercial example described herein. It stands out well in contrast, see *Fig. 8*.

Cathode Follower Circuit

Another degenerative feedback circuit, sometimes used in video amplifiers because of its wide band possibilities, is the cathode follower circuit shown in *Fig. 9*. In this case the load impedance being in the cathode circuit is also part of the input circuit therefore a natural degenerative feedback sets in. No amplification is accomplished since the voltage output is about equal to the input voltage. Instead, this circuit serves for high quality coupling between a high impedance source and a low impedance load.

Practical Feedback Circuits

Inverse or negative feedback may be applied to one, two, or three stages within the same amplifier. This means that the output voltage of the final stage of amplification may be fed back to the input side of that same stage, or to either of two preceding stages. It is quite usual to find feedback applied to one or two stages of amplification. Three stages of feedback however offer problems of instability due to the greater possibility of phase shift or delay occurring within

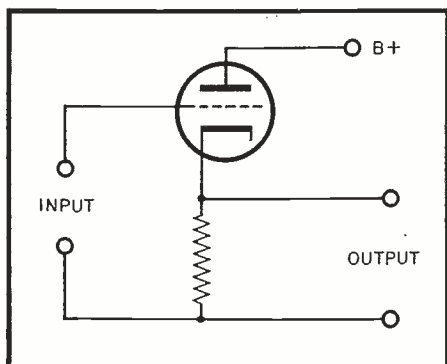

Fig. 9—Cathode follower.

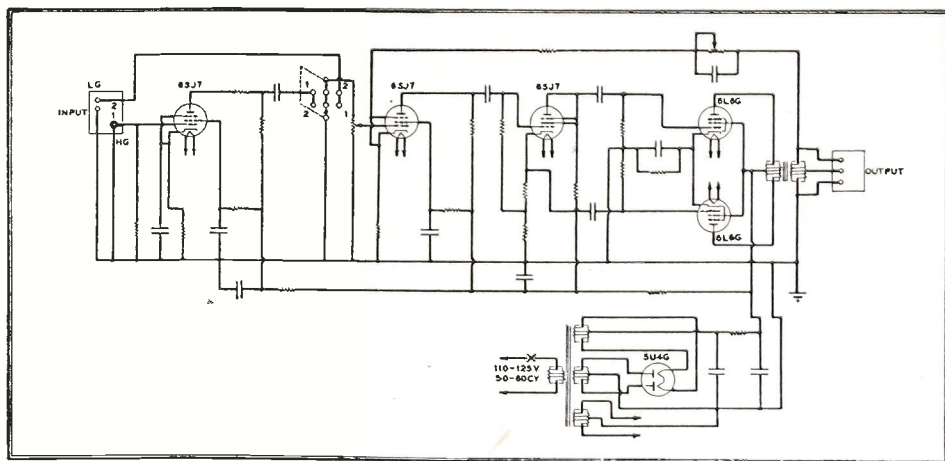

Fig. 7—Commercial amplifier schematic by Altec-Lansing.

the amplifier. A practical handling of three stage application will be seen in *Fig. 7* under Commercial Example in the next section.

Commercial Example

Having considered the meaning and behaviour of negative feedback and phase inversion, let us examine a well made commercial amplifier em-

ploying both. Such units have been developed out of necessity; developed to meet the challenge of the ever widening audio spectrum. The fuller frequency range capabilities of better modern duplex loudspeakers have demanded driving amplifiers of very high quality. Previously there has been, often rightly so, a decided preference for triode tubes with a low impedance output, rather than the use of beam power tubes where loudspeakers were to be operated. But the beam power tubes, as available today, have higher efficiency, greater power sensitivity, and less lum content thanks to indirect heaters. The amplifier under discussion (Altec Lansing A323) has a gain of 104 db and uses beam power 6L6 or 6V6 tubes in its push-pull output stage. Its schematic in *Fig. 7* shows a 6SJ7 tube, pentode connected, in the first stage. Another

Output Transformer

6SJ7, pentode connected, in the second stage drives a cathode-type phase inverter. This particular inverter uses another 6SJ7 triode connected and is capable of delivering 30 volts of driver power to the push-pull output stage. Constant stability and excellent balance is so obtained.

When beam power tubes are used in the final stage, the output transformer becomes a vital factor. If unsatisfactory, it can disrupt all that has been accomplished by the stages preceding it. The output transformer used in the amplifier of *Fig. 7* was designed for very low phase shift, high self impedance, an accurate balance between windings, low distributed capacity, and has a high coupling factor to reduce leakage. Only through such care is stability maintained over long periods of service. The gratifying result in this case is proven by the response curves of *Fig. 8*. Since these identical curves were taken at output levels 60 db apart, it is obvious that this amplifier is capable of performance over a 60 db range with no change in its frequency characteristics. More carelessly designed 15-watt amplifiers may only develop two or three watts of power in the lower or bass register. This unit develops 15 watts at 400 cps and, in the range from 40 to 10,000 cps, the output power will vary less than 1 db from the 400 cycle value. The switch between the first and second stages, (*Fig. 7*) eliminates the first stage affording a lesser gain of 74 db instead of 104 db as desired. This is by no means a new amplifier. There have been many of them in service for over two years. It is because they will stay in use for some time, and therefore will be encountered by servicemen, that this model was chosen for description.

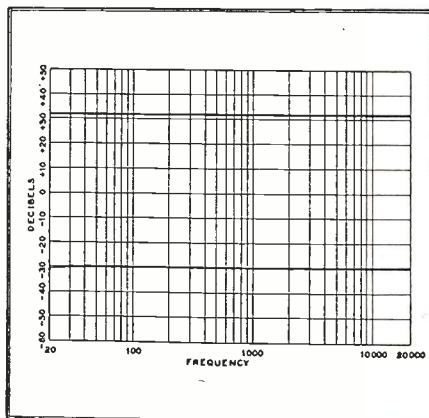

Fig. 8—Response curves.

ploying both. Such units have been developed out of necessity; developed to meet the challenge of the ever widening audio spectrum. The fuller frequency range capabilities of better modern duplex loudspeakers have demanded driving amplifiers of very high quality. Previously there has been, often rightly so, a decided preference for triode tubes with a low impedance output, rather than the use of beam power tubes where loudspeakers were to be operated. But the beam power tubes, as available today, have higher efficiency, greater power sensitivity, and less lum content thanks to indirect heaters. The amplifier under discussion (Altec Lansing A323) has a gain of 104 db and uses beam power 6L6 or 6V6 tubes in its push-pull output stage. Its schematic in *Fig. 7* shows a 6SJ7 tube, pentode connected, in the first stage. Another

Custom Building for HIGH FIDELITY

PART I

by DAVID T. ARMSTRONG

WHAT to do with those lack luster hours in between jobs is a problem many servicemen face. All too frequently they are wasted either by listlessly reading a newspaper, listening to some radio program, or by idly thumbing through catalogs. These idle hours would not be tolerated if the serviceman were working for someone else, and he should not tolerate them simply because he is self employed. There are many little jobs he can do which will improve his technical knowledge and skill and at the same time be productive of income. Here are some concrete suggestions:

Some people want quality radio reception at prices within the reach of a normal pocketbook. These are the individuals who might like custom built installations to fit into certain nooks. There are in reality limitless possibilities to what the intelligent and enterprising serviceman can do here to render service, cut down idle time, and make a profit that could eventually make him rich beyond the dreams of avarice.

To those really interested in quality John Ruskin used to say: "There is hardly anything in the world that some man can not make a little worse and sell a little cheaper, and the people who consider price *only* are this man's lawful prey." Many such quality-minded individuals have heard good FM and are wondering why they do not get the same quality reception on AM. It is actually possible within the range of AM, but radio receiver manufacturers have not been manufacturing high fidelity sets because they have been concentrating on selling the small five tube varieties, one for every room in the house, as well as a three way portable complete with batteries to take along on walking trips or picnicking.

Beginning a 2-part article on the various phases of high fidelity custom building for the serviceman. A step by step approach on the different units employed in this lucrative field is used.

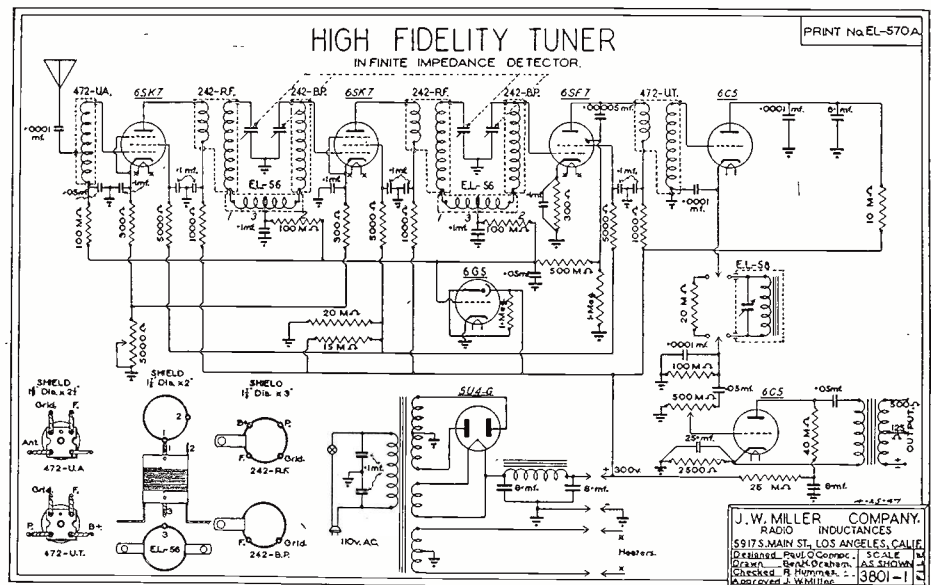

Fig. 1—Circuit diagram of J. W. Miller Co. High Fidelity Tuner.

High quality reception is possible with AM, FM, and TV, but it is not generally available to the public except at prices that are for the most part prohibitive. Actually so few fidelity receivers are made by the manufacturers that they are in reality almost custom made units adapted to small lot mass production and sold to the public at very high custom made prices. The enterprising serviceman can make up in his own shop in ordinary unproductive time a great many chassis for AM and FM and perhaps even for TV. The actual layout and wiring of such units will improve his knowledge of circuits, his skill in diagnosis, and his general

servicing techniques. How many service men have actually built a receiver recently, or ever built an FM unit? Isn't such a skill really fundamental to good servicing?

Radio has become such a keenly competitive field that inferior parts have been used in too many receivers to produce the kind of quality a critical listener now desires. That background of hum must go. Distortion should be cut to a minimum. Record reproduction should be of an exceptionally high level. Here are some suggestions as to how some of these desirable results may be achieved:

[Continued on page 41]



HYTRON REFERENCE GUIDE FOR *Miniature* ELECTRON TUBES



Type designation	Description	Prototype in larger envelope	Cathode & Ratings		Base connections	Overall height	Capacitances		Circuit application	Applied voltages			Screen curr. ma	Amp factor	Plate resis. ohms	Trans conduc. μ mho	Power output watts	Load resis. ohms	Cutoff bias volts	Type designation
			Type	Volts			Amps	G-P μ F		G-K μ F	P-K μ F	Plate								
0A2	Gaseous v regulator	003/VR150	Cold	--	5-B0	2 5/8	--	--	Voltage regulator	185 min	150 v	approx.	output through a current range of 5-30 ma.	--	--	--	--	--	0A2	
0A5	Cold-cath pentode	--	Cold	--	6-CB	1 5/8	--	--	Relay or trigger	Plate	750 v	Grid 3	90 v	2.1	100M	1500	10M	--	0A5	
0B2	Gaseous v regulator	0C3/VR105	Cold	--	5-B0	2 5/8	--	--	Voltage regulator	133 min	108 v	approx.	output through a current range of 5-30 ma.	--	--	--	--	--	0B2	
1A3	Vhf diode	--	Cath.	1.4	5-AP	2 1/8	--	0.4	H-w rect. or det.	Max plate	117 v rms at 10.5 ma d-c output	--	--	--	--	--	--	--	1A3	
1L4	R-f pentode	1N5GT	Fill.	0.05	6-AR	2 1/8	0.008	3.6	Voltage amplifier	90	90	0	4.5	2	360	350M	1025	--	1L4	
1R5	Pentagrid converter	1A7GT	Fill.	0.05	7-AT	2 1/8	0.4	7	Converter	90	67.5	0	2.9	1.2	600M	925	--	--	1R5	
1S4	Power amp pentode	1Q5GT	Fill.	0.1	7-AV	2 1/8	--	--	Power output amp	90	67.5	0	1.7	3	500M	300	--	--	1S4	
1S5	Diode a-f pentode	--	Fill.	0.05	6-AU	2 1/8	0.2	2.4	Detector & volt. amp	90	67.5	0	1.6	0.4	600M	625	--	--	1S5	
1T4	R-f pentode remote cutoff	1P5GT	Fill.	0.05	6-AR	2 1/8	0.01	3.6	Voltage amplifier	90	67.5	0	3.5	1.4	500M	900	--	--	1T4	
1U4	R-f pentode	1N5GT	Fill.	0.05	6-AR	2 1/8	0.008	3.6	Voltage amplifier	90	67.5	0	1.6	0.4	600M	625	--	--	1U4	
1U5	Sharp cutoff	--	Fill.	0.05	6-BW	2 1/8	--	--	Detector & volt. amp	Max plate	7800 v rms; curr. 10 ma peak, 2 ma avg.	--	--	--	--	--	--	--	1U5	
1Z2	Diode a-f pentode	--	Fill.	0.05	7-CB	2 1/8	0.3	0.6	Rectifier	Max plate	1000 v rms; curr. 9 ma peak, 1.5 ma avg.	--	--	--	--	--	--	--	1Z2	
2B25	H-w rectifier	--	Fill.	0.11	3-T	2 1/8	--	--	Rectifier	Max plate	350 v inv. peak; curr. 22 ma peak, 5 ma avg.	--	--	--	--	--	--	--	2B25	
2C4	Triode thyratron	--	Cath.	2.5	5-AS	2 1/8	1.3	2.2	Voltage amplifier	150	150	1300 v inv. peak; curr. 500 ma peak, 100 ma avg.	3.5	3	63M	3700	4.5	--	2C4	
2C51	Twin triode	7F8	Cath.	6.3	6-CJ	1 3/4	0.02	2.4	Relay service	250	90	-20	4.0	2.6	90M	1900	0.6	--	2C51	
2D21	Tetrode thyratron	2090	Cath.	6.3	7-BN	2 1/8	0.2	9.5	Power amplifier	135	90	-7.5	14.8	2.2	100M	1800	0.7	--	2D21	
2E30	Beam pentode*	--	Fill.	0.05	7-CQ	2 5/8	0.2	6.6	Power output amp	150	90	-8.4	13.3	2.2	100M	1800	0.7	--	2E30	
3A4	Power amp pentode	--	Fill.	0.2	7-BB	2 1/8	0.35	4.8	Power output amp	90	90	-2.5	3.7	15	8300	1800	--	--	3A4	
3A5	Power amp pentode	--	Fill.	0.1	7-BC	2 1/8	3.2	0.9	Voltage amplifier	90	90	-2.5	3.7	15	8300	1800	--	--	3A5	
3B4*	Twin triode*	--	Fill.	0.11	7-CY	2 1/8	0.16	4.6	Power amplifier	150	135	-7.5	9.5	2.1	1700	2100	1.1	--	3B4	
3B4*	Vhf beam pentode	--	Fill.	2.50	7-CY	2 1/8	0.16	4.6	Power amplifier	150	135	-7.5	9.5	2.1	1700	2100	1.1	--	3B4	
3C4	Power amp pentode	3Q5GT	Fill.	1.25	7-BA	2 1/8	0.41	5.5	Power output amp	90	90	-4.5	7.7	1.7	215	100M	2150	0.27	3C4	
3S4	Power amp pentode	3Q5GT	Fill.	0.05	7-BA	2 1/8	--	--	Power output amp	90	67.5	-7	7.4	1.4	100M	2000	0.24	--	3S4	
3V4	Power amp pentode	3Q5GT	Fill.	0.1	7-BA	2 1/8	--	--	Power output amp	90	67.5	-7	7.2	1.5	100M	1425	0.27	--	3V4	
6A55	Power amp pentode	6H6GT	Fill.	1.4	6-BX	2 1/8	--	--	Power output amp	90	90	-4.5	7.7	1.7	100M	2000	0.24	--	6A55	
6A65	R-f pentode	--	Cath.	2.8	7-BD	2 1/8	0.025	6.5	Voltage amplifier	250	150	R _k =200	7	2	800M	5000	--	--	6A65	
6A66	Sharp cutoff	6SH7GT	Cath.	6.3	7-BD	2 1/8	0.03	10	Voltage amplifier	100	100	R _k =100	5.5	1.6	300M	4750	--	--	6A66	
6A67	R-f pentode	6AC7	Cath.	6.3	7-CC	2 1/8	0.03	10	Triode v amp	150	150	R _k =160	10	2.5	500M	9000	--	--	6A67	
6A68	Sharp cutoff	--	Cath.	6.3	7-CC	2 1/8	0.02	4.1	Voltage amplifier	28	28	R _k =200	3	1.2	250	90M	2750	--	--	6A68
6A69	Sharp cutoff	--	Cath.	6.3	7-CC	2 1/8	0.02	4.1	Class AB ₁ power amp	180	75	-7.5	6.1	4.5	--	--	--	--	6A69	
6A70	Sharp cutoff	--	Cath.	6.3	7-CC	2 1/8	0.02	4.1	Voltage amplifier	180	120	R _k =200	7.7	2.4	350M	5100	--	--	6A70	
6A71	Power amp pentode	--	Cath.	6.3	7-CC	2 1/8	0.12	3.6	Power output amp	180	120	R _k =200	7.5	2.5	1700	340M	5000	--	--	6A71
6A72	Twin diode	6H6GT	Cath.	6.3	7-BK	2 1/8	0.12	3.6	Power output amp	180	180	-9	15	2.5	400	190M	2300	1.1	--	6A72
6A73	Power amp pentode	6H6GT	Cath.	6.3	6-BT	1 3/16	--	--	F-m discriminator	135	135	-6	11.5	2	360	170M	2100	0.6	--	6A73
6A74	Power amp pentode	6A67	Cath.	6.3	7-B0	2 1/8	0.05	9	Rectifier	120	120	-6	35	12	--	12500	8000	--	--	6A74
6A75	Quadruple diode	--	Cath.	6.3	7-B0	2 1/8	--	--	Power amplifier	250	250	-12.5	45	4.5	218	52M	4100	4.5	--	6A75
6A76	Beam pentode	6V6GT	Cath.	6.3	7-B2	2 5/8	0.35	7.6	Rectifier	250	250	-12.5	45	4.5	218	52M	4100	4.5	--	6A76
6A77	Duplex diode	6T7G	Cath.	6.3	7-BT	2 1/8	1.8	1.7	Detector & volt amp	180	180	-8.5	29	3	58M	3700	2	--	6A77	
6A78	Power amp pentode	6K6GT	Cath.	6.3	6-CC	2 5/8	--	--	Power amplifier	100	100	-3	1	0.8	70	61M	1150	--	--	6A78
6A79	Beam pentode	7A5	Cath.	6.3	7-CV	2 5/8	0.6	12.0	Power amplifier	150	250	-18	32	5.5	68M	2200	3.4	--	6A79	
6A80	R-f pentode, dual control, sharp c.o.	--	Cath.	6.3	7-CM	1 3/4	0.02	3.9	Voltage Amplifier	180	117	-8.5	35	2	--	--	4500	--	--	6A80
6A81	Duplex diode	6Q7GT	Cath.	6.3	7-BT	2 1/8	2.1	2.3	Detector & volt amp	250	250	-3	3	3	70	58M	1200	--	--	6A81
6A82	R-f pentode	6SH7GT	Cath.	6.3	7-BK	2 1/8	0.0035	5.5	Voltage amplifier	250	150	-1	10.8	4.3	70	58M	1200	--	--	6A82
6A83	Sharp cutoff	6S07GT	Cath.	6.3	7-BT	2 1/8	2.1	2.3	Detector & volt. amp	100	100	-2	1.2	2	100	60M	3900	--	--	6A83
6A84	Duplex diode	6S07GT	Cath.	6.3	7-BK	2 1/8	0.0035	5.5	Voltage amplifier	250	100	R _k =68	11	4.2	100	80M	1250	--	--	6A84
6A85	R-f pentode	6S07GT	Cath.	6.3	7-BK	2 1/8	0.0035	5.5	Converter	250	100	R _k =68	11	4.2	100	80M	1250	--	--	6A85
6A86	Pentagrid converter	6SB7-Y	Cath.	6.3	7-CQ	2 5/8	0.19	9.5	Voltage amplifier	100	100	-1	3.6	10.0	1000M	950	--	--	6A86	
6A87	R-f pentode remote cutoff	6SK7GT	Cath.	6.3	7-CQ	2 1/8	0.004	4.3	Power amplifier	100	100	-3	9	3.5	700M	2000	--	--	6A87	
6A88	Pentagrid converter, remote c.o.	6SA7GT	Cath.	6.3	7-CH	2 1/8	0.3	7.2	Converter	250	100	-1.5	2.8	7.3	1000M	475	--	--	6A88	

TV QUIZ NO. 1

by DAVID GNESSIN

BEFORE ANSWERING THE QUESTIONS — READ THESE RULES:

This quiz, based upon information made available by courtesy of the Howard W. Sams Photofact Television Course will prove of value to all radiomen interested in reviewing TELEVISION. For those who possess the Sams course a reference to the page involved is given in parenthesis after each question number. Readers should write out the answers, copy the diagrams for practice, and circle correct answer if multiple choice is given.

After quiz is completed, compare with answers given elsewhere as indicated. Save these quizzes. They will cover the entire Sams' course and are applicable to the review of television regardless of special technical background of reader.

Look for the next quiz in next month's RADIO SERVICE DEALER. The series will run indefinitely.

1. (p 3) The horizontal scanning circuit of the Cathode-Ray Tube must produce in one second a sufficient number of cycles to scan every line in every frame occurring within that period. This scanning frequency is:

- (a) 30 cycles per second
- (b) 60 cycles per second
- (c) 120 cycles per second
- (d) 15,750 cycles per second
- (e) 31,500 cycles per second

2. (p 3, 4) One of the following factors is not fundamental in the makeup of the C-R tube:

- (a) An electron beam source
- (b) Provision for controlling the brilliance of spot
- (c) Spot focus control
- (d) Amplification factor
- (e) Deflecting provision
- (f) Fluorescent screen

3. (p 5) Note Fig. 1. Practically all television receivers list on the front a knob, called, *Brilliance, Brightness, or Intensity Control*. This controls the brilliance of the image appearing on screen. Although several functions in the receiver can affect this phenomenon, exactly which element in the C-R tube is directly indicated by the Brilliance Control:

- (a) Anode #1
- (b) Anode #2
- (c) Control Grid
- (d) Supply Voltage
- (e) Focus

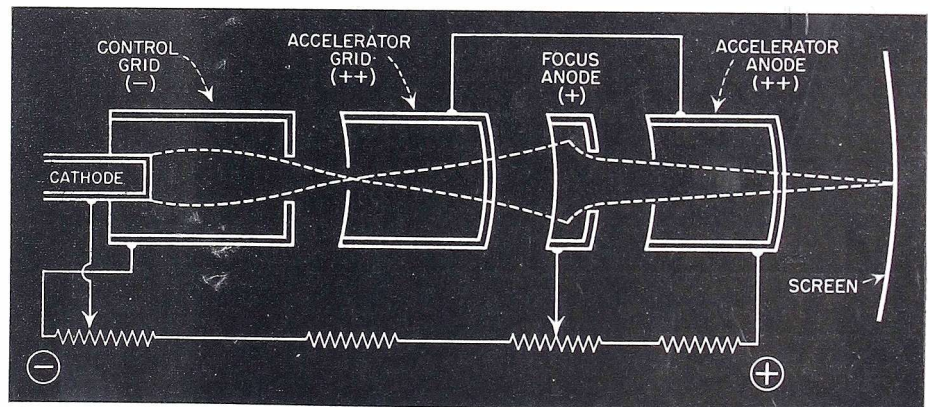

Fig. 1—CRT Electron Gun Assembly

4. (p 5) Short of actual failure of C-R tube elements, one factor alone causes the picture to blank out periodically, as a necessary part of television operation, to avoid a continuous blur appearing on the screen. Which single C-R tube element causes this *blackout*, as you can easily determine by experiment by varying its control:

- (a) Power-supply cycle
- (b) Filament-supply cycle
- (c) Critical Anode voltage
- (d) Phosphor discharge on screen
- (e) Critical Cathode emission point
- (f) Control Grid bias

5. (p 5) In common with electronic tubes of all types, the C-R tube control grid varies the current in the

electron stream. (See Fig. 1) It has another single significant function:

- (a) Causes the beam to have a cross-over point after passing grid aperture
- (b) Catches the loose ions which would otherwise damage the face of the tube
- (c) Aligns the electrons into parallel streams for scanning
- (d) By-passes ripple voltage which would otherwise modulate electron beam
- (e) Suppresses the d-c component of the electron beam, permitting only the useful a-c component for picture definition

[Answers to these questions will be found on page 40]

BASING DIAGRAMS - BOTTOM VIEWS OF SOCKET CONNECTIONS

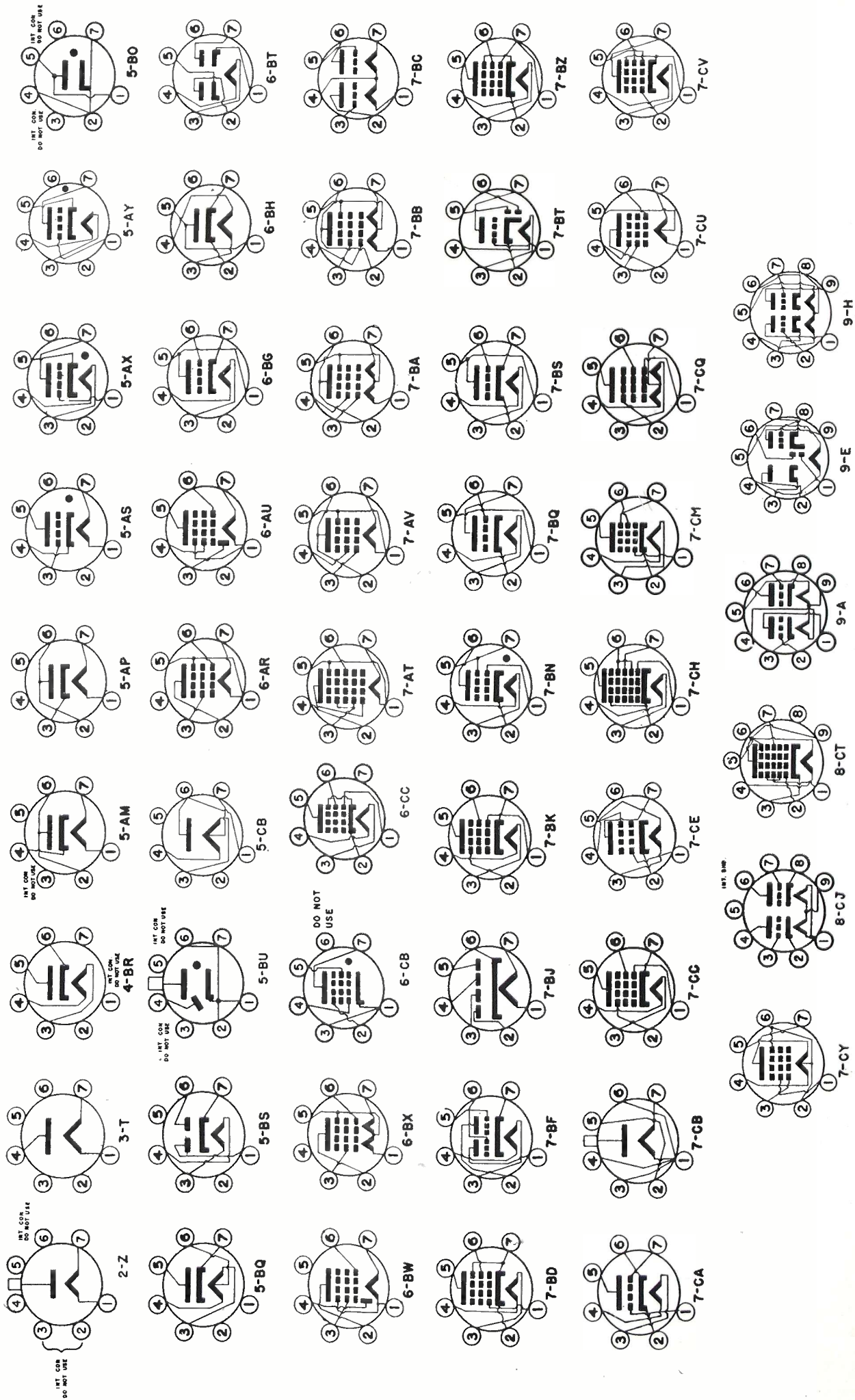

NEW H-F RESONANCE INDICATOR

McMurdo Silver Co., Inc., of Hartford, Conn. announces the addition of a new instrument to its test equipment line—Model 915 (patent pending) which is intended to be used with Model 906 Signal Generator of this company's manufacture. This novel unit converts any signal generator/test oscillator to a direct

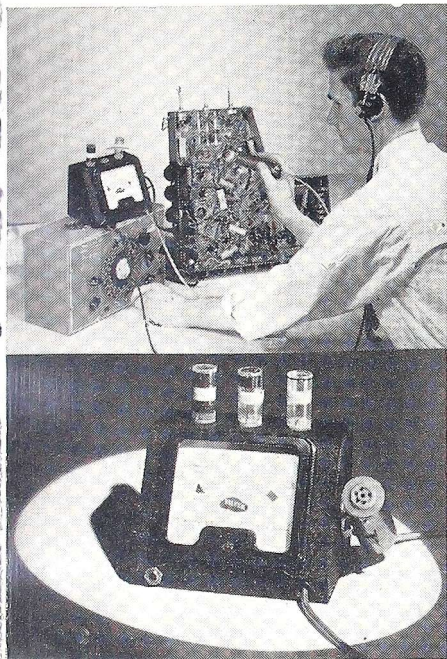

reading resonance indicator. This instrument has a continuance frequency range of 100 kc. thru 300 mc. by the use of three especially designed probe coils.

Model 915 which aroused considerable interest at the New York I.R.E. Show is directly available from all Silver jobbers.

RCA INDOOR TV ANTENNA

This new indoor television antenna, just announced by the RCA Tube Department, will be welcomed by apartment dwellers and others in urban areas who may have been denied the pleasures of television because of restric-

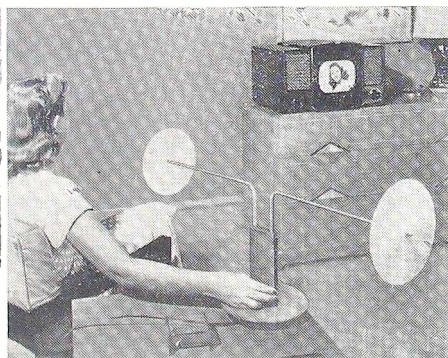

tions on outside antennas. The new antenna is easily attached to the television receiver and may be oriented by hand for best reception. It is lightweight, portable, and attractively designed to blend with home or office furnishings.

NEW DOUBLE-NEEDLE CARTRIDGE

The Astatic Corporation, Conneaut, Ohio, announces a new LQD Cartridge which uses two separate, independent needles, one with one-mil tip radius to play the new long-play-

NEW PRODUCTS

ing records, and the other needle with three-mil tip radius for standard recordings. These are the Astatic "Q" and "Q-33" needles, which have been available for some time and are readily obtainable in the field.

A gentle pry with a penknife or small

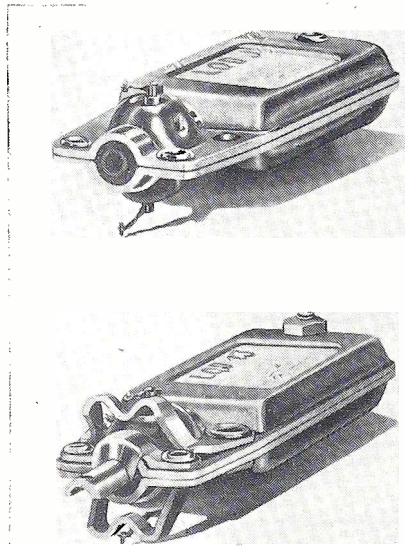

screw driver lifts either of these special needles from its snap-in position in the cartridge, without removing the cartridge from the tone arm. Gentle pressure with the tip of a knife blade clicks the new needle into place. Removing or replacing one needle does not disturb the other.

CONVERTS PHONE TO MICROGROOVE

An economical, simple device called the Micro-Verter manufactured by Microverter, Inc., 53 Park Pl., N. Y. 7, N. Y., comprising a speed-reducing turntable and a feather-

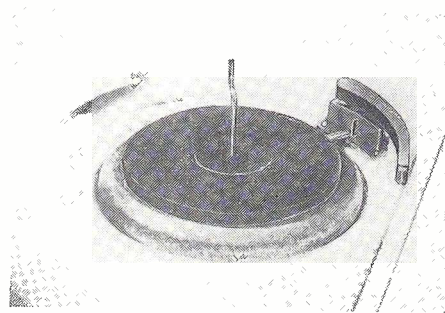

weight pickup arm assembly is now on the market. By being placed inside the phonograph, the Micro-Verter makes it possible to play the new 33 1/2 RPM Columbia 12", 10", and 7" Microgroove records in addition to the 78 RPM conventional record. This new device converts present record players to dual speed to play Columbia Microgroove records.

NEW 4-WAY STAND

A new Model 432 Combination 4-Way Banquet and Floor Stand is announced by Electro-Voice, Inc., Buchanan, Michigan.

This new 3-section Microphone Stand can be used in a variety of ways to meet varying needs of any sound set-up on the spot: (1) Banquet Stand; (2) Chair-Height Stand; (3) Conventional Floor Stand; (4) Easily portable.



It utilizes a single-section, 2 sections, or 3 sections, as the case may be. Banquet Stand height is 19" retracted to 34" extended. Chair-Height Stand is 26" retracted to 41" extended. Floor Stand height is 44" retracted to 59" extended. Can easily be changed from one type or the other as needed, and includes many other desirable features.

NEW TRANSVISION ANTENNA

Transvision announces a newly designed TV Antenna which receives all television channels. It eliminates the need for two separate ant-

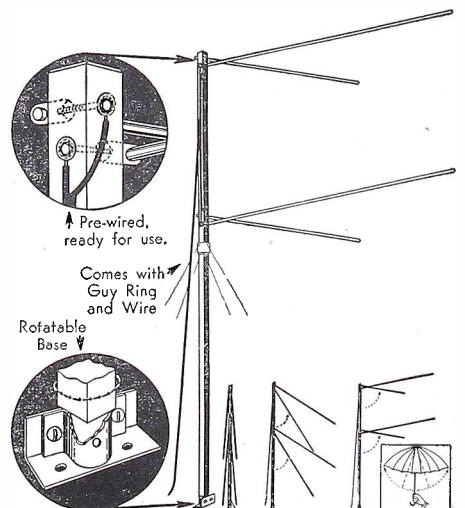

enna installations for the High and Low TV bands; therefore no coupling losses. This antenna is trade marked "Flip-Up" because of the ease and speed with which it can be set up.

[Continued on page 29]

FREQUENCY & WAVE METERS

Copyright 1949 Cowan Publishing Corp.

Mfgr.	Model	Frequency Range	Other Features	Wt. Lbs.	Size Inches
Measurements Corp.	59	2.2 Mc-400 Mc	Grid dip frequency meter—can be used as marker signal for TV—or wave meter	6½	5½ x 6½ x 7½
McMurdo-Silver	903 Wavemeter	1.6 Mc-500 Mc	Can be used as field strength meter with 903A meter	1½	3½ x 3½ x 3½
Triplett	3256 Wavemeter	3.4 Mc-30 Mc	Designed for amateur band	1	3½ x 5½ x 2½
Browning Labs.	MJ9	7 Ham Bands	.05% accuracy. Audio detection		
	MJ 15	LF—.1-12 Mc HF—10-250 Mc	In 5 bands for each unit. Grid dip osc. Absorption wavemeter. Het. det.		
	S4	1.5-70 Mc	High accuracy freq. meter (.0025%)		
	S5	30-500 Mc	High accuracy freq. meter (.0025%)		
	S6	.1-50 Mc	Freq. meter accuracy .025%		
	S7	72-76 Mc 152-162 Mc	High accuracy freq. meter (.0025%)		
S8	13.6-27.32 40.98 Mc	Measurements of freq. in diathermy bands			

TELEVISION CALIBRATOR

Mfgr.	Model	Frequency Range	Output Volts	Other Features	Wt. Lbs.	Size Inches
RCA	WR 39A	<ul style="list-style-type: none"> • Tunable Oscillator: 4 bands: 19-110 Mc 2 bands: 1 0-240 Mc • Harmonics of 0.25 and 2.5 Mc crystals from 250 Kc to 250 Mc 	0.1 RMS	Primary crystal std.-2.5 Mc, accuracy 0.01% Modulating Crystal std.-0.25 Mc (can be zero beat against 2.5 Mc crystal), accuracy 0.03% Heterodyne detector and amplifier operate self-contained speaker or ext. ear phones	15	10 x 13½ x 7½

RESISTANCE-CAPACITANCE BRIDGES

Mfgr.	Model	Type	Capacity Range	No.	Resistance Range	No.	Other Features	Wt. Lbs.	Size Inches
Aerovox	76	Wheatstone Bridge	100 µf to 200 µf	6	10-20 Meg	6	Leakage and Power Factor tests	8	10 x 7¼ x 8¼
McMurdo Silver	904	Carey-Foster Bridge	10 µf to 1000 µf	4	10-1000 Meg	4	Leakage and Power Factor tests		
Sprague [Tel-Ohmike]	TO-3 De Luxe	Wheatstone Bridge	10 µf to 2000 µf	4	2.5-25 Meg	4	Leakage and Power Factor tests	15	13¼ x 10½ x 5

AUDIO OSCILLATORS

Mfgr.	Model	Type	Output Milliwatts	Output Imp. Ohms	Freq. Range Cycles	Other Features	Wt. Lbs.	Size Inches
R.C.A.	WA54A	Beat Frequency	125 (High level)	Balanced 250, 500, 5,000 Unbal. 62.5, 125, 1,250	20-17,000	Temperature compensation Electron eye output indicator Voltage-regulated power supply Load-matching output transformer	22	10 x 13½ x 7½
Supreme	680	Beat Frequency	500 at 5,000 ohms	250 at 5,000	15-15,000	Neon lamp zero beat indicator	21	13¼ x 9 x 6¾
Sylvania	145A	RC (Wein Bridge)	1,000 at 500 ohms	8 at 500	20-20,000	Feedback compensation Tapped primary: 108-129, 130-155, 200-240 volts	27½	11½ x 17¼ x 9¼

NEW PRODUCTS

[from page 27]

Mast of the antenna has been designed of non-conducting material which prevents possible grounding and reduction of signal strength. It has unusually high mechanical strength and is extremely rigid when installed. Guy ring and guy wires provided for added rigidity.

Completely assembled with rotatable base, 7 ft. mast, guy ring and guy wire. Additional 7 ft. masts, to build antenna up to 19 ft., are available at small extra charge. Additional information can be obtained by writing to: Transvision, Inc., New Rochelle, N. Y.

NEW SYLVANIA TUBE LINE

A new line of specially-processed receiving tubes for replacement service in television receivers has been announced by Sylvania Electric Products Inc.

The new line of tubes is being offered to meet the critical needs of television receivers. They were designed to reduce the number of service calls now required for tube replacements.



The new line includes miniature, GT, and Lock-In styles, including: 1B3GT, 6AG5, 6AL5, 6BG6G, 6J6, 6K6GT, 7B4, 7B5, 7C5, 7F7, 7H7, 7N7, and 7Z4.

The new tubes are identified by an orange branding, "Sylvania Television Tube", and new orange and green cartons.

Shielded 300 Ohm Line

New 300 ohm, shielded, balanced lead-in cable, which minimizes noise, "snow" and

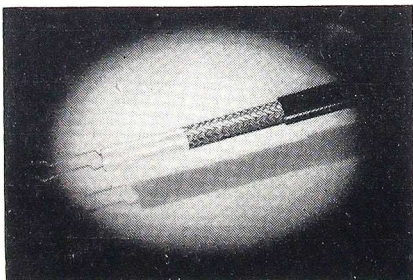

"ghosts", induced in transmission lines, developed by Federal Telephone and Radio Corporation, East Newark, New Jersey.

WARD TV INDOOR ANTENNA

The Ward Products Corporation, a Division of the Gabriel Co., 1523 E. 45th St., Cleveland 3, Ohio, is making available their new TVI-43 indoor antenna. The Ward TVI-43 is attractive, blending well with the most exact-

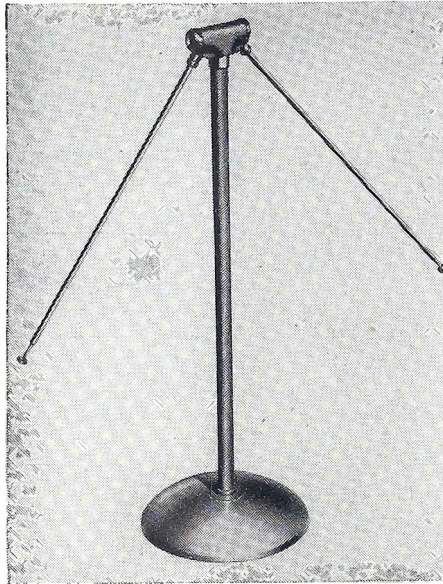

ing interior. Chrome-plated brass telescopic dipoles, satin beige brown finish. It is carefully engineered and weighted, so that it will not tip over. Although it will extend to a full 7 feet 9 inches, it is constructed with unique compactness for easy storage.

NEW WALCO NEEDLE

The attached photographs shown the new Walco Model WP-30 Muted Stylus Needle in its gold foil package.

Shure Brothers, Inc. have sold several million of their Muted Stylus pickup cartridges to many of the country's largest phonograph manufacturers, and have licensed Electrovox



Company, Inc., 60 Franklin Street, East Orange, N. J. to manufacture and sell to the retail trade the specially designed Muted Stylus Needle which is necessary for use with this cartridge.

The Walco Muted Stylus Needle has a Precious Metal tip and will render about one hundred hours of use before replacement is necessary.

NEW TV INDOOR ANTENNA

Tricraft Products Company, 1535 N. Ashland Avenue, Chicago, Illinois, manufacturers of antennas for FM and Television, announce their new inside model television antenna, Model 600.

Incorporating new design and operation features, the Model 600 needs no mechanical



adjustments to change stations—is electrically tuned to the station—and only requires a turn of the switch for the channel desired. It's easy to use and instantly ready for operation.

ANTENNA ACCESSORY

The LaPointe Plascomold Corporation, Unionville, Connecticut, announces that it is now in production on a Split Guy Ring as il-



lustrated below. This Split Guy Ring makes it possible to add additional sets of guy wires to already existing installations where increased strength is desired.

INDOOR TV ANTENNA

R. M. Karet Associates Inc. 510 N. Dearborn Street, Chicago, announce their appointment as exclusive national sales representatives for the new Hi-Lo indoor television antenna manufactured by Ferris Television Labs. of Chicago.

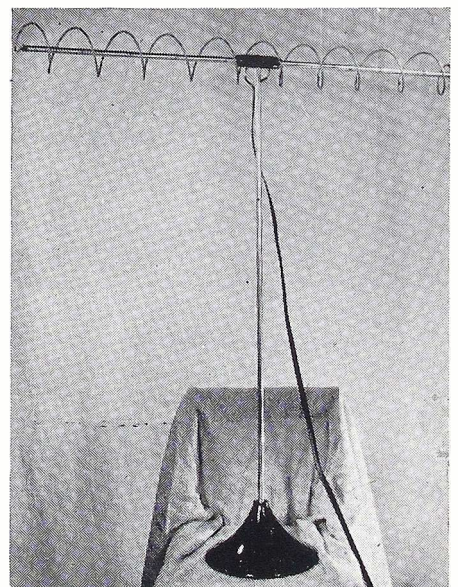

The new antenna features 12 channel coverage without requiring adjustment of any kind except orientation.

Six months of field tests have proven an extremely high degree of sensitivity under all kinds of operating conditions.

SIGNAL TRACERS

Copyright 1949 Cowan Publishing Corp.

Mfr.	Model	Channel Freq./Sens. (Measured Values)		Other Functions	Wt. Lbs.	Size Inches
		R.F.-I.F.	Osc.			
EICO Multi-Analyst	113A			Electronic Voltohmmeter Checks R.F.-I.F.-A.F.	15	11 x 7 x 8½
Electronic Products Company	Dynamic Signaller			Contains Multivibrator Signal Source Ranging from 5,000 cycles to the V.H.F.	5	6½ x 7 x 7
Feiler Stethoscope	TS-2 (battery) TS-3 (a.c.)			R.F. V.T.V.M. Circuit Checks R.F.-I.F.-Audio Circuits	10½	8 x 11½ x 6
Feiler Stethoscope	TS-7			5" C.R.O. Visible and Aural Signal Tracer V.T. input calibration device for measuring voltage	38	17½ x 15 x 9½
Hickok Traceometer	156A	95-1600 Kc 5000 μV (full scale)	600 Kc -15 Mc	Electronic voltmeter Wattmeter Checks A.F. 20-20,000 cycles (1 volt sens. full scale)	32	14 x 16½ x 11
McMurdo Silver Sparx	905A			Checks R.F.-I.F.-A.F.	14	12¾ x 7¾ x 5¾
Radio City	777			Checks R.F.-I.F.-A.F. to 150 Mc 10,000 μV (full scale) checks A.F.	9½	6½ x 8½ x 11¼
R.C.A. CHANALYST	162 C	96-1,700 Kc/ 80 μV RMS A.F. up to 50,000 cycles 0.1 RMS sensitivity	600-15,000 Kc Wattage: 30-250 watts	Electronic voltmeter channel Zero center d-c meter Input resistance 11 megohms. Can be used as tuned a-c volt- meter over all Chanalyst fre- quency ranges.	28	9 x 16 x 10¾
Supreme AUDOLYZER	688	95 Kc to 14.5 Mc		Electronic Volt-Ohmmeter Checks A.F. Gain	32	15½ x 11½ x 8¾
Test Craft	TC-75			Checks R.F.-I.F.-A.F.		7 x 11 x 5

ERRATA

The foregoing charts were prepared from the specifications of 226 instruments submitted by 37 manufacturers, and entailing more than 5,000 items which had to be evaluated and categorized. "To err is human"—and—the following is a list of CORRECTED specifications:

Issue	Page No.	Chart	Mfr.	Model No.	Heading	Corrected Specification
Feb. 1949	15	Oscillo-graphs	R.C.A.	WO-58A	Amplifier Frequency Response	Flat within 20% from 5 cps to 2 megacycles. Down 50% at 4 Mc.
Feb. 1949	18	Electronic VOM	R.C.A.	WV-75A	Input Resistance	11 megohms
Feb. 1949	18	Electronic VOM	R.C.A.	WV-95A	Other Features	Current Range 10 microamperes to 10 amperes
Feb. 1949	18	Electronic VOM	Simpson	Shown as Model 226 should be Model No. 266		
Feb. 1949	18	Electronic VOM	Weston	769	Ranges— D.C. Volts	3-1,200 volts.
Feb. 1949	18	Electronic VOM	Weston	769	Ranges— Ohms, Lo-Hi	2K-2,000 M ohms
Feb. 1949	18	Electronic VOM	Weston	769	Ranges— A.C. Volts, Lo-Hi	3-1,200 volts
Feb. 1949	18	Electronic VOM	Weston	769	Other Features	Contains r-f probe. Battery or a-c operation.

Beanstalk? . . . No! But like the proverbial Beanstalk
RADIART SIMPLI-FLEX ANTENNA *Sales*
HAVE *Shot Up* **OVERNIGHT**

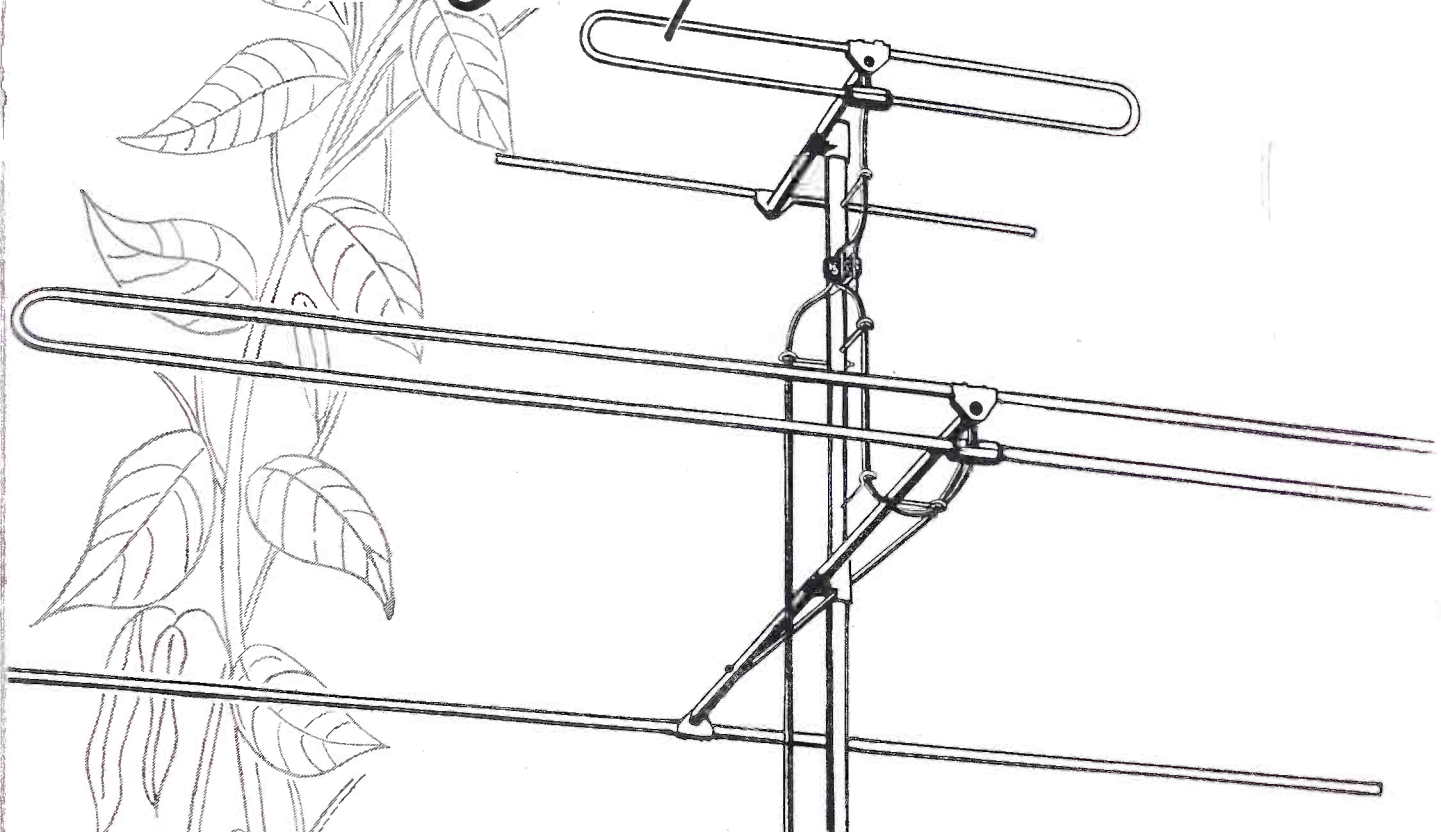

Wondering what all the excitement is all about? What is it that has shot up so quickly in demand? It's the RADIART line of SIMPLI-FLEX antennas! Practically overnight . . . like the proverbial beanstalk . . . these antennas have grown and sky-rocketed in popularity and taken the country by storm!

AND . . . the answer is simple enough . . . ELECTRICALLY . . . they out-perform all others—MECHANICALLY . . . they are easier to install, and more sturdy when installed!



IT'S RIGHT . . . WHEN IT'S RADIART



THE RADIART CORPORATION
CLEVELAND 2, OHIO
Manufacturers of the Famous Red Seal Vibrators

TRADE FLASHES

[from page 12]

Dealer distribution of the pre-recorded wire will be launched shortly, according to R. F. Blash, Webster-Chicago President, who revealed that the Company has been working on the pre-recording problem for the past two years.

Auto Speaker Chart J-28 . . .

Permoflux Corp., 4900 W. Grand Ave., Chicago, Ill. This auto speaker replacement data chart shows replacement speakers for practically all auto radio sets now in existence.

Those engaged in auto radio servicing will find this chart a most valuable source of information. For your copy just write for data chart #J-28.

Espey Alarm Clock Receiver

Model 524 is a 4 tube (plus rectifier tube) Superheterodyne Radio Receiver with synchronous alarm clock, designed to operate on 110/120 volts AC, 60 cycles. This receiver covers the Standard Broadcast Band from 540 to 1700 Kc.

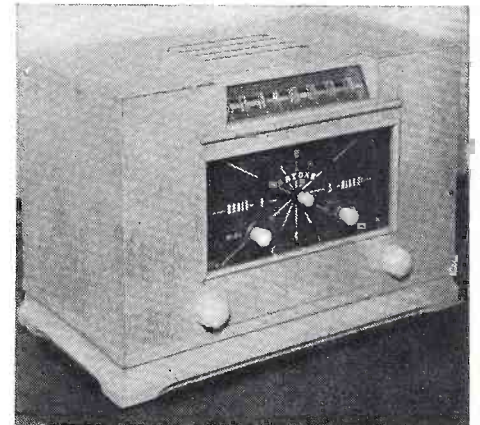

Its features include: a superheterodyne circuit, a PM speaker with Alnico V magnet, automatic volume control, full-range volume control, a lighted "slide-rule" dial, licensed under RCA patents, RMA listed, 4 finest quality tubes (plus one rectifier tube), 2 dual-purpose tubes which give 6 tube performance, a built-in loop antenna with provisions for external antenna, an acoustically engineered, bleached mahogany cabinet, suitable for all climates, and a self-starting, synchronous alarm clock.

New Hardware Package

There's a "new look" for radio hardware packaging in the new Walsco "99 Line". It represents the first attempt to introduce a new era in modern hardware merchandising.

[Continued on page 34]

Each OF THESE MICROPHONES
HAS THE **SUPER-CARDIOID**
PICKUP PATTERN THAT
REDUCES FEEDBACK BY **73%**



LIST PRICE
\$67.50

THE FAMOUS "55" UNIDYNE DYNAMIC

Unidirectional Microphone. This superlative dynamic microphone is a Multi-Impedance Microphone—you can have either High, Medium, or Low Impedance simply by turning a switch! Because it is a Super-Cardioid, the "Unidyne" kills Feedback energy by 73%—making it possible to use under the most difficult acoustic conditions. The "Unidyne" is probably the most widely used microphone throughout the world. Recommended for all highest quality general-purpose uses.

Multi-Impedance Switch
for Low, Medium or High
Impedance.



LIST PRICE
\$39.75

THE NEW "737A" MONOPLEX CRYSTAL

Unidirectional Microphone. The "Monoplex" is the *ONLY* Super-Cardioid Crystal Microphone made. As such, it is undoubtedly the finest of all crystal microphones. (A comparative test will prove this statement convincingly.) The "Monoplex" employs the same type of acoustic phase-shifting network used in the highest cost Shure Broadcast Microphones. Has "Metal Seal" crystal—will withstand adverse climatic conditions. Can be used in those applications where severe background noise would make conventional microphones practically useless!

Licensed under patents of Brush Development Company. Shure patents pending.

SHURE BROTHERS, Inc.

Microphones and Acoustic Devices



225 West Huron Street, Chicago 10, Illinois • Cable Address: SHUREMICRO

SRO

**has a
new meaning
now!**

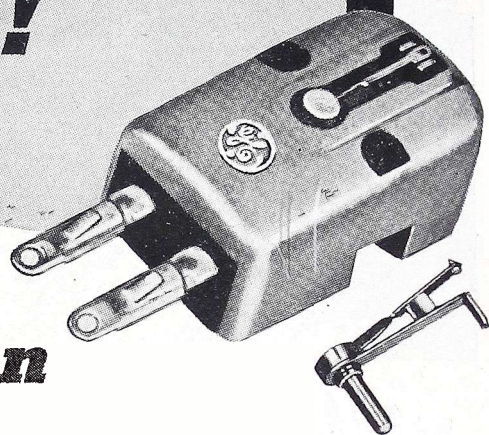

Stylus Replacement Often

WHEN the big attraction hit town they hung the "Standing Room Only" sign—it meant overflow business.

It still means that, but the big attraction now drawing overflow business for distributors and dealers is the G-E Variable Reluctance Cartridge with the Replaceable Stylus.

Why? Because record fans who know their records best wanted the finest reproduction possible. The G-E Variable Reluctance Cartridge gave them just that. To secure peak performance they often replaced the cartridge when the stylus was only slightly worn.

Now, with the Replaceable Stylus, cartridge replacement is no longer necessary. In four easy steps the cartridge can be removed from the tone arm, the stylus changed and listening pleasure increased.

Economy is the big feature but this redesigned cartridge has many other advantages. Smaller in size, it can be adapted to many

more tone arms. Higher lateral compliance provides more faithful tracking, hence better fidelity. Frequent stylus replacement reduces record wear and adds hours of top listening pleasure. Needle talk and needle scratch are negligible, giving cleaner, finer reproduction.

Best of all, the cartridge is available for either the new LP records with 1 mil stylus or for conventional records with the 3 mil stylus.

Now for the *Big Extra* to step up sales! A neat dispensing unit for the counter with two cartridges and six styli recessed in a gold-flocked panel to catch the eye. The entire unit is finished in an attractive blue and has a compartment in the rear for additional stock. It is a silent salesman that keeps selling. See your distributor right away for details.

For complete information on Variable Reluctance Cartridges and Replaceable Styli write to: *General Electric Company, Electronics Park, Syracuse, New York.*



The counter sized dispensing unit for greater sales—7½" long, 5½" wide, 4¾" high at the back.

You can put your confidence in—

GENERAL



ELECTRIC

McMurdo
SILVER

IS FIRST AGAIN!



NEW! TUBELESS GRID DIP ADAPTER

THIS OUTSTANDING ELECTRONIC INVENTION brings to the engineer, serviceman and amateur a single accurate means of determining circuit function. The utility of any signal generator, test oscillator or v.f.o. is expanded many times. Allows direct measurement of all tuned circuits: r.f., i.f., etc., simply and quickly without the receiver being turned on. Checks all oscillators: antenna systems: transmitters: trap circuits: without mechanical coupling. Determines the value of all coils and condensers. Requires no power supply or tubes: two simple connections permit quick attachment to any signal generator you are using. Covers the continuous frequency range from 100 kc. through 300 mc. by use of the three calibrated plug-in coils provided. Equipped with a phone jack for easy aural identification of oscillator frequencies. Model 915 has no equal as a field strength monitor or grid dip oscillator. Handsomely styled, complete with compact probe and plug-in coils,

\$34.95^{NET}

MODEL 906 FM-AM SIGNAL GENERATOR

This advanced type signal generator stands out as today's greatest electronic value. Continuous coverage from 90 kc. through 210 mc. Accuracy $\pm 1\%$. Less than $\frac{1}{2}$ microvolt including strays to over 1 volt metered output. AM modulation adjustable from 0-100%. FM sweep from 0-1200 kc. Complete with all accessories **\$116.50** at a low net price of only



MODEL 911 TV-FM SWEEP GENERATOR

Here is an all-in-one TV service center. Continuous range of 2 thru 226 mc. Output from 0- $\frac{1}{2}$ volt. 1 and 5 mc. precision crystal markers insure pin-point setting of TV i.f. band width, and trap circuits. Phased 60 cycle sine and 120 cycle saw-tooth voltages for direct scope control. Sweep from 0-10 mc. An outstanding buy at only **\$78.50**

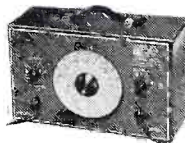

Look to McMURDO SILVER for the NEWEST in FM-TV Service Equipment

SEE US AT BOOTH 41 AT THE CHICAGO SHOW

Send for Catalog

See these and other McMURDO Silver LCETI instruments at your favorite jobber.

OVER 37 YEARS OF RADIO ENGINEERING ACHIEVEMENT

McMurdo Silver Co., Inc.

EXECUTIVE OFFICES: 1240 MAIN ST., HARTFORD 3, CONN.
FACTORY OFFICE: 1249 MAIN ST., HARTFORD 3, CONN.

Designed primarily to eliminate the time-consuming tasks of counting and weighing, the new "99 Line" now includes over 150 individually packaged radio hardware items, each in attractive plastic containers.

A complete list of the numerous items available in the Walsco "99 Line" may be obtained by addressing the Walter L. Schott Company, 9306 Santa Monica Boulevard, Beverly Hills, California.

RCA Projection

RCA's new life-size television projection system (TLS-87) features an "out-of-the-way" ceiling mounting for the barrel-shaped projector. The con-

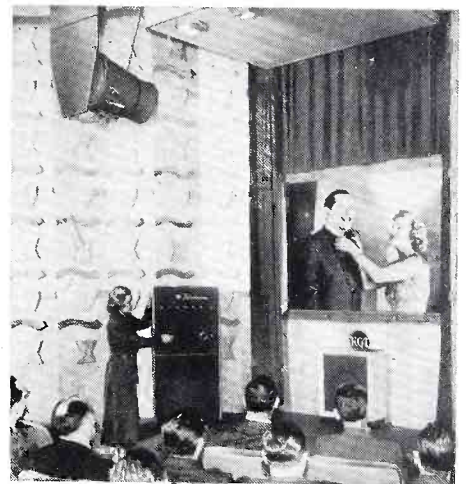

trol console, which is connected to the optical barrel by a 40-foot cable, can be built-in if desired, or placed in any convenient location.

New Air King TV

Air King Announces New Television Console. . . Air King Products Company, Inc., Brooklyn, announced the addition of a new Console model to its line of "Spotlite-Brite" television receivers. Model A-1001 will feature a Direct View 10" Tube, mounted in handsome hardwood mahogany or blonde cabinet.

Simplified TV Kit

Television Assembly Co., makers of television kits for direct view tubes from 10" up to 20" as well as a projection TV receiver with a 520 sq. in. screen, have announced that their direct view sets will now be delivered with all major components mounted including their prewired I.F. picture and sound strip (pat. pending) which they call their "VIVIDEO" feature. Front ends will also come prewired. That leaves only 13 tubes to be wired. In addition, new "Super-simplified" instructions are included which involve an entirely new and different method of presentation. According to Mr. Joe Snaider, T.A.C. head, even one who has no knowledge of the

simple rudiments of radio can assemble a complete receiver, as shown by test after test. The fact that pre-alignment and pre-tuning are already built into pre-wired sections accounts for the remarkable results.

Rider Canadian Rep.

John R. Tilton, eastern Canadian representative for John F. Rider Publisher, Inc., now assumes the broader role of Rider representative to the entire Dominion of Canada.

CIRCUIT COURT

[from page 25]

the world. Many sets depend on the use of external devices to drop the voltage when used on the higher voltage lines.

The elements of the power supply circuits are shown in the partial schematic illustrated. It will be observed that one side of the power line connects to the common ground in the normal manner. The other side of the line is seen to be divided into three branches. Each branch has a series resistor which is in the circuit for high voltage operation but is shorted by one section of a three-gang switch for low voltage use.

One branch, supplying the d-c for the set, utilizes a 25Z6 rectifier tube and single-section L-C filter. The dropping resistor in this circuit is 1250 ohms, in the high voltage condition. A 4 mfd. electrolytic capacitor shunts the resistor to provide hum reduction.

Another branch, this one with a 1500 ohm resistor, operates the four 120 volt pilot lights in series-parallel.

The third branch, with two 188 ohm resistors for high voltage use, supplies the heater string. Additional resistors of 100 and 10 ohms are in the circuit on both voltage settings

FIELD FINDINGS

[from page 8]

genuinely interested in the repairman and the replacement business to shout loudly in RMA's ear that we are an important part of the overall radio industry, and we too are entitled to a part of the RMA overall accumulation of funds. Every RMA member who is a parts, tube or test equipment manufacturer should cooperate and have set up in RMA a committee to fight for the rights of the serviceman. It would be a simple matter to present facts to RMA justifying the need for "Preventive Maintenance Month" and the appropriation of RMA (and NAB) funds for such a purpose.

Heard Here and There

Feb. 2 San Francisco. H.C. Bonfig, Zenith vice-president, made a couple of statements in his address to dealers



BRACH

TV ANTENNAS

build your **PROFITS**

these **3** ways

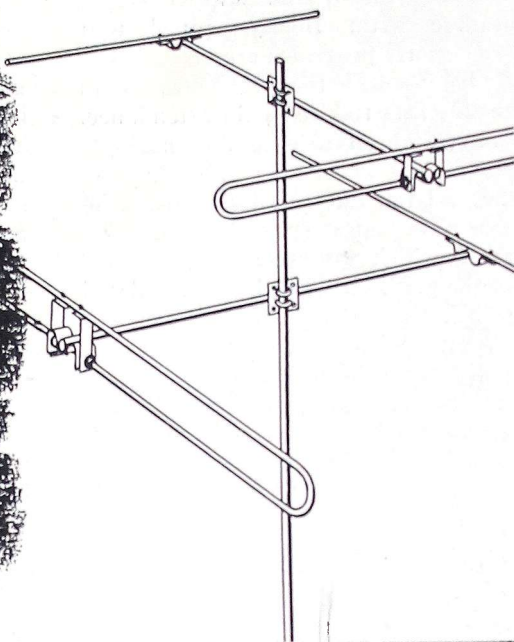

1. SAVE INSTALLATION TIME. Actually save enough for additional installations each week. Simplicity of Brach Antenna design, together with maximum pre-assembly at the factory, take whole hours of "time-on-the-roof" off your installation costs. And, for easier, quicker, on-the-job handling, Brach TV Antenna Kits are individually packaged, complete with all necessary hardware. Brach Universal Base Mount is a real time saver.

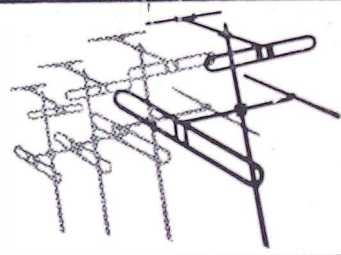

2. ELIMINATE EXPENSIVE CALL-BACKS. Brach quality engineering and bulldog ruggedness combine to help make your initial installation completely satisfactory. Developed by a name as old as radio itself, Brach TV Antennas are products of the manufacturer's own laboratory. From the rugged structural steel base mount to the tip of the sturdy mast, they're designed to stand up and shrug off the worst the weather has to offer—and deliver superior reception—longer. Factory pre-tuned and matched for 300-ohm transmission line, all Brach Antennas feature large-diameter aluminum elements for better signal pick-up.

3. MAKE PURCHASERS YOUR BEST SALEMEN. The future success of your television line depends upon the success of your past installations. There's a Brach TV Antenna to meet every television problem better. Each Brach array you install puts you further ahead of your competition performance-wise.

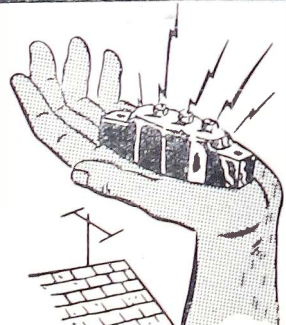
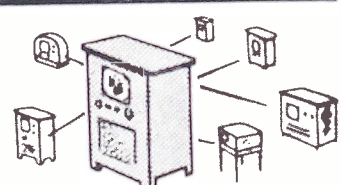

**A NECESSARY EXTRA
BRACH LIGHTNING & STATIC ARRESTER #4004**

Helps keep the buck and jump out of the image when due to static discharge. Protects certain delicate receiver parts. Complete with all necessary hardware, the Brach Rare Gas Arrester is easily attached to any downlead. Constructed of porcelain and non-corrosive metal parts. Tested and listed by Underwriters' Laboratories.

SEND FOR BRACH CATALOG NO. D1304



L. S. BRACH MFG. CORP.

200 CENTRAL AVENUE, NEWARK, N. J.

WORLD'S OLDEST AND LARGEST MANUFACTURERS OF RADIO ANTENNAS AND ACCESSORIES

attending the Winter Market that I disagree with. Bonny opined that many sports programs are being taken off TV because the promoters found the telecasts reduced paid attendance. I haven't been able to find a single sports-event promoter who agrees. They all tell me TV has been a life-saver to many sports events and arenas which would have folded had not the public interest been stimulated by TV.

Bonny also stated that dealers should get behind FM set sales and that station Radio Diablo is blanketing most of central California. All through the mid-west and far-west Service Dealers told me that their

local FM programs are so bad, with over 90% of the programming being inferior records and loaded with hammy commercials, that most FM set buyers, after using their new sets a short while, bring them back and demand a refund or a conventional AM set as a substitute. And in California, many Service Dealers tell me that while Radio Diablo is a "terrific station" they are having a helluva time making satisfactory FM installations because the hilly terrain out there causes freak dead spots. However, getting experience in making FM installations is fine because soon TV will hit out there and all the know-how obtained now will pay off.

Philco Awarded Citation

Feb. 13, Harrisburg, Pa. Today, Larry Helk, representing the Federation of Pa. Servicemen's Associations awarded Jim Skinner, Jr., vice-prexy of Philco, the Federation's annual award to the firm that had during the past year given most help to the servicing profession. (It seems that Philco disseminated all the data available on TV service techniques, held service classes, and did not set up their own TV service organizations, preferring to let independent service organizations take on all the available installing jobs). Well, Larry said some nice things about Philco, and in responding, Jim Skinner said some nice things about radio servicemen. So, for the first time in my 23 years of experience in this business I have heard the two extremes, manufacturer and servicer, pat one another on the back. It was such a unique experience that I promptly went into a "lost weekend".

Incidentally, the radio servicing profession owes Norm Cooper, service manager for Stewart-Warner a nod of recognition. Last July Norm submitted a proposal to RMA regarding TV installation and maintenance work and manufacturers' warranties that I still believe is the answer to the whole problem. (See "RSD" July 1948 editorial). That RMA is still biding a decision on the Cooper proposal is hard to understand. Perhaps when next they meet we'll get action.

Mar. 2, Kansas City, Mo. Yours truly was afforded the privilege of addressing several hundred technicians at the Electrical Developments Forum which was held in conjunction with the Week of Electrical Progress. TV is coming to Kansas City this Fall and the way the K. C. Chamber of Commerce, Electric Association and parts jobbers who are members of it prepared for the event is worth noting.

The various groups got together with Central Radio & TV School. A fund was established whereby the Association paid part, and the technicians who were interested in taking the course paid a small fee too. Then, for several months, several nights each week, a complete course in TV training was given. Several dozen technicians took the course, and now as a result TRT (Television & Radio Technicians) is in existence and ready to serve Kansas City with competent TV installers and repairmen. This Association is going to set the pattern that other cities, soon to have TV, should follow. If you are interested, write to R.J. Samson, executive manager of The Electric Association

GENERAL INDUSTRIES leads the L.P. Parade...

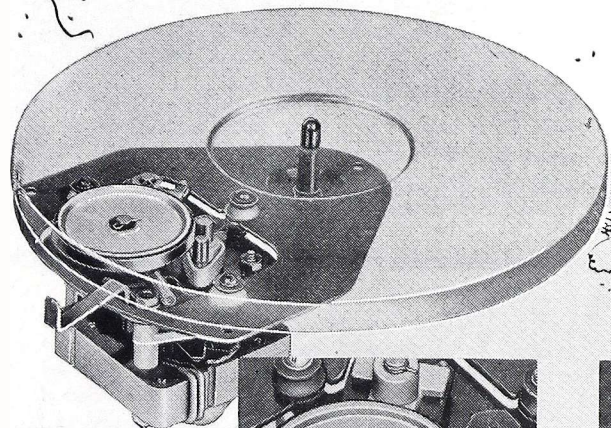

MODEL DM—

Compact 2 pole, shaded pole motor, being widely used by many leading radio and record-changer manufacturers. Simple speed change mechanism incorporates a special long-lasting molded neoprene belt.

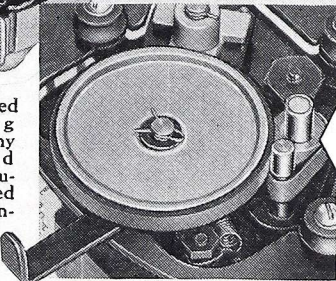

78
RPM

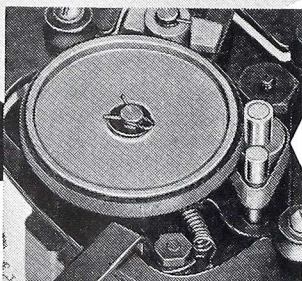

33 1/3
RPM

with a low cost, rim drive DUAL SPEED PHONOMOTOR FOR BOTH 33 1/3 AND 78 R.P.M. RECORDS

It's L.P. for *Larger Profits* when your record-changers and record-players will handle both the new long-playing microgroove and conventional 78 R.P.M. records. And it's General Industries—oldest name in the phonomotor field—which offers you an economical turntable unit to capture this popular, profitable market.

Like all GI Smooth Power products, this motor has undergone tests far more rigid than service conditions encountered in normal use. It is the result of years of research and development . . . built to exacting performance standards, but surprisingly low in cost.

General Industries offers prompt delivery of this motor in quantity lot shipments. For additional information, specifications and quotations, write *today*.

In addition to the Model DM, General Industries also manufactures a Model DR rim drive dual speed phonomotor. It is a heavy-duty 4-pole shaded pole motor for use where the ultimate in performance is desired. Novel speed change mechanism is both simple and positive in operation.

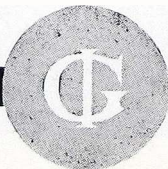

The GENERAL INDUSTRIES Co.

DEPARTMENT K • ELYRIA, OHIO

HOW to trouble - shoot and test FM-Television Receivers... FASTER

Which of These FERRET Instruments Do You Need NOW?



FERRET Signal Tracer
Electronic Volt Ohm Meter (Model 730)

Including sub-miniature 6K4 Diode Connected Probe Incorporates these advanced and exclusive features: Audio & R.F. Measurements to 300 MC; high gain signal tracer; 1 Volt R.F. Scale. This combined signal tracer and vacuum tube volt-ohm-meter has many features not found in any other similar instrument in commercial use today. Its 1 volt R.F. scale, for instance, is an exclusive feature. Remarkably low priced for an instrument of this class.

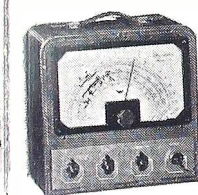

FERRET Audio Oscillator
Sine Wave—Square Wave (Model 730)

Range (20 to 24,000 cycles on three bands) permits higher frequency tests than are possible with other instruments now in use. Actually incorporates two units in one. Provides laboratory standard measurement for all frequency response in design and commercial sets. Lightweight; low priced. Send coupon for complete details.

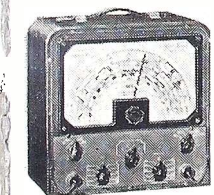

FERRET Signal Generator
(Model 701)

Wide range amplitude modulated signal generator, so universal in scope it serves the varied needs of modern radio servicing of both high and low frequency receivers. Frequency range 170 K.C. to 110 MC on fundamentals. Harmonic Band to 220 M.C. Internally modulated from 0-100%. Provision for External Modulation. Fully Attenuated—Ladder and Fine Attenuators. Many other new features. Send coupon today for complete information.

Will Test Equipment You Buy Today Serve You Next Year?

With the rapid changes and developments taking place in Television—you, as a business man, must consider what the money you invest today in equipment will do for you in long range service.

Ask yourself this question: "What test equipment will still be useful on the new television receivers one year from today?"

The answer must be FERRET EQUIPMENT because FERRET is the most advanced, most completely developed test equipment so far produced, either commercially, or in the laboratory. There is no other type of test equipment which embodies all the advanced-design features that FERRET offers.

It is important to you as a business man to investigate the advantages FERRET offers you today that will continue to serve you through all the rapid changes that are coming in television receivers.

Send the coupon today for the complete, full story of the FERRET line.



FERRET De Luxe Test Speaker-Universal Substitutor

(Model 721)

Conservatively rated components used throughout this instrument, designed to eliminate all necessity for removing set speaker from midget radios, consoles, auto radios. Great time-saving feature. Will handle more power output with fidelity than any other test speaker in the field today. Will match output impedances of all audio output tubes regardless of set age.

Built-in resistor, paper condensers, electrolytic condensers, and field resistances, for substitution. Get the valuable free information. Mark and send the coupon today!

Make More PROFIT with FERRET Advanced-type Test Equipment, Saves You Time, Improves Work

You can make more profit with Ferret advanced-type test equipment because FERRET's built-in advantages give you the very newest and best in modern electronic design and engineering. You can work better, faster, make more profits with this better equipment!

FERRET TEST EQUIPMENT embodies every war-tried and post-war perfected electronic development. Precision built to service every test requirement of all modern FM and Television receivers, currently in use or in laboratory development stages.

Extremely portable, lightweight, compact, all FERRET

EQUIPMENT is of lightweight aluminum construction throughout; finished in blue-gray Hammettone, with leather handles. The complete FERRET line is matched for efficiency and fine appearance. FERRET costs no more, in some cases much less, than comparable equipment—FERRET equipment gives you more advanced test features, precision operation, and guaranteed accuracy. Send for complete information about the values FERRET has for you. Check the items you are especially interested in on the coupon below and mail it today!

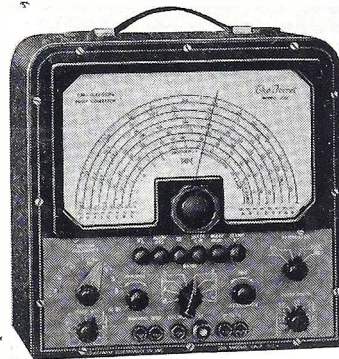

New FM-Television Sweep Generator Simplifies Tests

FERRET brings you one of the latest electronically-controlled television sweep generators yet developed, a sweep generator with all the very newest, (many exclusive) test features.

The FERRET SWEEP GENERATOR, Model 720, for instance, has a 20MC sweep width, twice the rated sweep of any other instrument of its class yet developed. Its range extends from 0 to

260MC on fundamentals; it has a variable marker oscillator, 19 to 20 MC, with built-in internal crystal marker, absorption marker c. w. marker and modulated marker with provision for externally modulating carrier to 260 megacycles.

Pre-tested for extreme accuracy on all bands, this revolutionary instrument is the answer to quick, efficient testing of all current and laboratory-planned TV equipment. Lightweight, very portable, remarkably low priced. Send for full information. Mail the coupon below today.

FERRET Germanium Crystal Probe

New streamlined Germanium crystal, lightweight probe. Will not deteriorate, or wear out with normal use. High impedance. Doubles value of conventional VTVMS by extending use through RF. No filament power used. Frequency response 20 kilocycles to 110 megacycles accurate within five percent. Complete information on request. Send coupon.

FERRET Equipment

COASTWISE ELECTRONICS CO., Inc.

130 N. Baudry Ave. — Los Angeles 12, Calif.

FREE Complete Information About Advanced-Design FERRET EQUIPMENT. Check and mail this coupon today!

Coastwise Electronics Co., Inc.,
130 N. Baudry Avenue, Dept. N-449
Los Angeles 12, Calif.

Please send me without obligation full information about FERRET EQUIPMENT checked. (Check all items of interest).

- | | |
|---|---|
| <input type="checkbox"/> Ferret Sweep Generator | <input type="checkbox"/> Ferret Signal Generator |
| <input type="checkbox"/> Ferret Signal Tracer-Electronic Volt Ohm Meter | <input type="checkbox"/> Ferret De Luxe Speaker-Universal Substitutor |
| <input type="checkbox"/> Ferret Audio Oscillator | <input type="checkbox"/> Ferret Germanium Crystal Probe |

Name.....

Address.....

City.....State.....

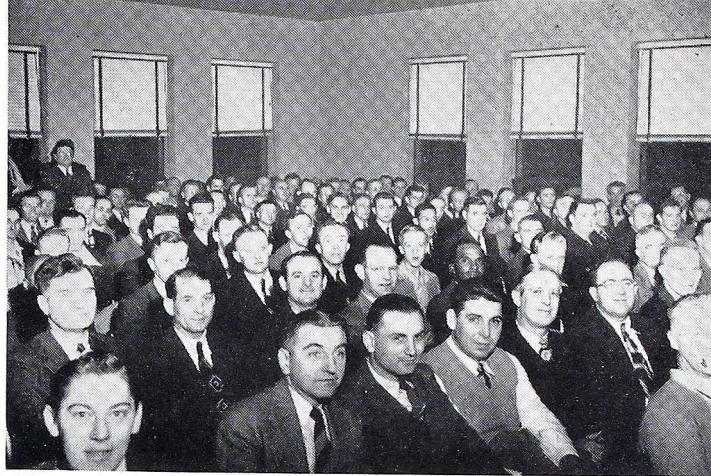

LEFT: Service Meeting at which John F. Rider, Manual Publisher, was the featured speaker. RIGHT: Technicians were addressed by Al Saunders, representing Howard W. Sams, Photofact Publisher.

Regulate Your Line Voltage to fit Your Needs

- On 117 V. line, variable from 95 to 145 Volts. If line drops to 90, variable from 75 to 115 Volts.
- Output adjustable in 1½ volt steps.
- Metered out-put Voltage.
- 140 Watts, max., 50-60 cycle.

Here is a Voltage regulating isolation transformer that will make your bench test voltage exactly what you want... Only \$15.00... Capacity 140 Watts max. Every service engineer needs it for more accurate work and time saving short cuts.

Vari-volt Junior... \$15.00 DEALER NET

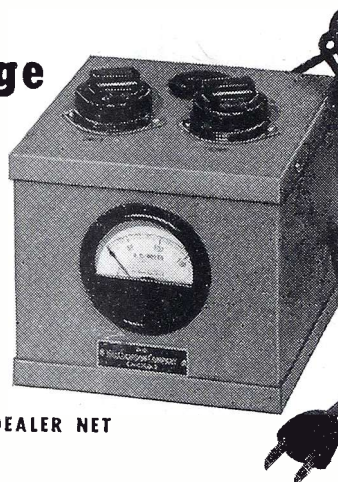

PARTIAL LIST OF USES

Radio and Television receiver testing at under or over voltage.
Speed up or retard heating of light soldering irons.
Excellent control for primary of high voltage breakdown transformers.

Controlled voltage for meter calibration.
To isolate "hash" and live ground from AC-DC Equipment.
For Schools and educational laboratories.
Adjusting line voltage to photo lamps for uniform exposure, and many other uses.

OTHER NEW HALLDORSON TRANSFORMERS

P-2067—Power—117 volts to 240-0-240 @ 60 M.A.—6.3 @ 2.75A.

P1596B—Isolation—115V. to 115V.—150 Watts.

P-2040—Stepdown—230V. to 115V—1000 Watts.

T-4303—Step-up—117V. to 140V.—12 Watts, (plate voltage booster for AC-DC sets)

N-91—Vibrator—6V. to 250V. @ 50 M.A. (CAN-3.04" x 2.4" x 2.2")

S-210—Plate Trans.—1150-500-0-500-1150 @ 150 M.A.

TELEVISION UNITS

L-211—Power—365-0-365 @ 250 M.A. D.C.—5V. @ 3A.—5V. @ 2A.—6.3V. @ 6A.—6.3V. @ .8A.

D41-611—Horizontal Blocking Oscillator (Replacement for RCA type No. 208T1).

D4-612—Vertical Blocking Oscillator (Replacement for RCA type No. 208T2).

J-96—Vertical Output Trans. (Replacement for RCA type No. 204T2).

C4-216—Choke—2 hy. @ 200 M.A.—D.C. Resistance Approx. 60 Ohms.

For more complete information write

THE HALLDORSON CO., 4500 Ravenswood Avenue, Chicago 40, Ill.

Halldorson
Vacuum Sealed Transformers

of Kansas City, 106 W. 14th St., K.C. 6, MO. for details.

Mar. 4, Chicago, Ill. Walking down State Street I met a friend. "Sandy, would you like to buy almost any kind of TV set at 30% off list?" he asked. "How can that be", I replied, "when dealers don't get that high a discount." Then I got the answer to the sharp price-cutting wave that has afflicted Chicago and many other towns in the mid-West. It seems that a few big electrical appliance-radio distributors got over-loaded with merchandise, particularly with washing machines, ironers and refrigerators. They needed cash quickly. No matter how much they cut prices on the electrical goods, no one would buy. So, to save their necks these outfits began to unload video sets. It seems a shame that this happened because it gave the general public the idea that TV sets are distress merchandise, which is far from being the case.

There is no doubt but that most radio retailers are following the foolish policy of selling TV sets at discounts in order to take a fast profit. I hardly suppose that set manufacturers will all attempt to prevent this from continuing by price-fixing their lines, but, it wouldn't be a bad idea. However, as an alternative, it might be a fine idea for TV makers to re-examine their dealer setups and restrict their franchises to a smaller number of dealers in every community.

Mar. 10, New York. Just wound up a 4 day stint at the I.R.E. Convention held here at Grand Central Palace. Everyone admitted that if it weren't for TV this business would be kaput. Almost every new item shown was allied to TV. In a nutshell, the industry realizes that video stations are not going to be able to increase their signal outputs for years to come and that means that the antenna business is going to continue to ride on the crest of prosperity. (Until videocasts are shot out with terrific power no firm will be able to make a satisfactory TV set having built-in antennas). And as long as outside antennas are going to be the proper way to get

★

“Buy U. S. Savings Bonds during the Opportunity Drive,”

★

SAY THESE LEADING AMERICANS

WILLIAM GREEN, *President,*
American Federation of Labor

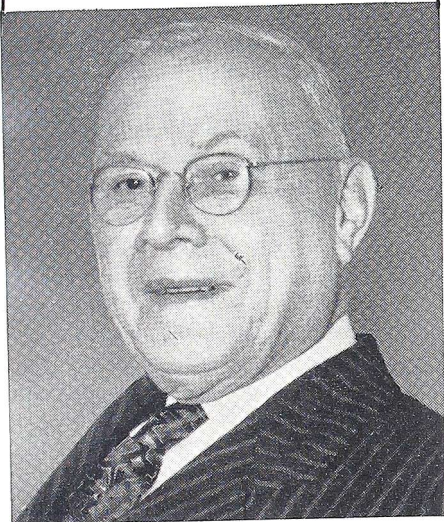

“For the working man, an increased investment in U. S. Savings Bonds can mean not only increased security but increased ability to take advantage of the opportunities that are part of the American way of life.”

WINTHROP W. ALDRICH, *Chairman,*
Chase National Bank



“I believe that every individual who can possibly do so should buy more U.S. Savings Bonds. These bonds represent one of the best investments of our time.”

PHILIP MURRAY, *President,*
Congress of Industrial Organizations

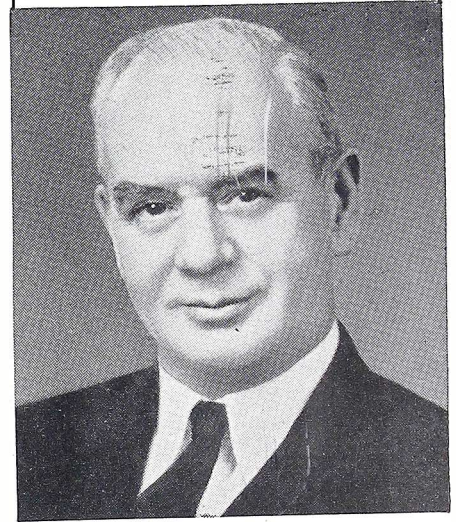

“The C.I.O. has endorsed every effort to encourage the worker to put more of his earnings into U. S. Savings Bonds. They represent both security and independence.”

CHARLES F. BRANNAN
Secretary of Agriculture

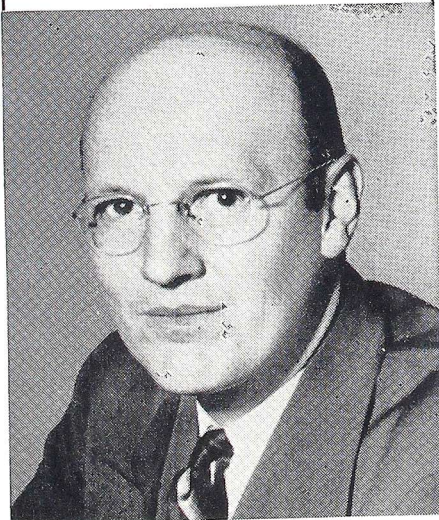

“I am heartily in favor of the Opportunity Drive to buy more U. S. Savings Bonds. Everyone engaged in farming should recognize the importance of a backlog of invested savings as a means of realizing the agricultural opportunities of the future.”

DURING MAY AND JUNE, the U. S. Savings Bond Opportunity Drive is on!

It is called the Opportunity Drive—because it is truly an opportunity for *you* to get ahead by increasing your own personal measure of financial security and independence.

If you haven't been buying Savings Bonds regularly, start *now*.

If you have been buying them, add an *extra* Bond or two to your purchases this month and next. Remember—you'll get back \$4 for every \$3 in a short ten years' time!

*Put More Opportunity
in Your Future...*

INVEST IN U. S. SAVINGS BONDS



Contributed by this magazine in cooperation with the Magazine Publishers of America as a public service.

BACK NUMBERS of "RSD"

Order them now - the supply is low.

JANUARY 1946

Applying Neg. Feedback in Audio Amps.
New Philco FM Circuit
RMA Resist. & Conds. Chart

FEBRUARY 1946

Applying Neg. Feedback in Audio Amps.
Service Market in Industrial Electronics
Ballast Tube & Plug-in Resistor Chart

APRIL 1946

Modern Tube Testing, Part 1, Methods
Servicing Sound Systems
Short-cuts on Intermittants by use of
"Substitution Block"

JUNE 1946

Modern Tube Testing, Part 2, Instruments
Short-cuts in Trouble-Shooting
Ohmmet., Cond-Testers, Cap-Met., Part 2

JULY 1946

Distortion—Determining the Cause, Part 1
Ohmmeters, Cond-Testers, Cap.-Met. Part 2
Multivibrators

AUGUST 1946

How Is Your Grid Biased? Part 1
Distortion—Determining the Cause, Part 2
Sound Distribution Systems

SEPTEMBER 1946

Transconductance-Reading Tube Tests
How Is Your Grid Biased, Part 2
Centralized Radio Servicing

NOVEMBER 1946

The TV Opportunity—Installing & Servicing
Don't Miss "Hidden" Profits, Part 1
Service Market in Industrial Electronics

DECEMBER 1946

Modernizing Sets by Using New Rectifiers
Deflection Generators in TV
Guide for Miniature Electron Tubes
Answers to FM Servicing Problems

FEBRUARY 1947

Simple Methods to Determine Impedances
Servicing Record-Changers
How To Block Interference

MARCH 1947

Antenna Multicouplers
Servicing P-A Installations
Trade Standards for TV Installations
Industrial Maintenance

MAY 1947

Oscillator & Power Supply Troubles
Ion-Trap in C-R Tubes
P-A System Design & Applications, Part 1

JUNE 1947

Simplified Set Checking
P-A System Design & Applications, Part 2
TV Installing Is A Specialty Business
Servicing 3-Way Portables

JULY 1947

Frequency Modulation, Part 1, antenna
fundamentals & signal shifting effects
Automatic Gain Control Circs. in TV Sets
Using Conventional Sig. Gen. for FM Align.

AUGUST 1947

TV R-F Circuits Described
FM, Part 2, receiver circuit fundamentals
TV Antenna Installation Problems

SEPTEMBER 1947

Substitution Boxes Lick Service Problems
TV Antennas for Multi-Unit Dwellings
FM, Part 3, Discrim. & Deaccentuation
Nets.

OCTOBER 1947

Add Record-players to Modernize Old Sets
P-A Fundamentals & Complexities
Modern TV Kits

NOVEMBER 1947

TV Antennas—Their Characteristics &
Applications

Bookkeeping Simplified
Make A Universal Test Speaker
Eliminating Cathode Heater Hum from
Audio Amplifiers

DECEMBER 1947

A New TV Set Servicing Technique
Ratio Detection & Its Applications
External Cross Modulation—Its Cause &
Cure

JANUARY 1948

Master vs Indoor TV Antennas
Audio Extractor for Signal Generators
TV Kit Alignment Procedures
70 Volt Speaker Distribution Line

FEBRUARY 1948

High Speed Servicing
Visual Alignment
Income Tax Deductions

MARCH 1948

Know Your Tube Tester
TV Power Supplies
A-C/D-C Battery Set Circuits

APRIL 1948

Video I-F Circuits & Applications
Computing What Price to Charge
Using 'Scopes For Radio Servicing

MAY 1948

FM Set Alignment Procedure
Video Detectors
How Vectors Simplify Servicing
Significance of Power Factor and ϕ

JUNE 1948

Amplifier Checking by Signal Injection
Applications of Gas Type Tubes
Modern TV Kits

JULY 1948

Television's Service Outlook
Video Amplifiers
Bad Acoustics Cured Electrically

SEPTEMBER 1948

De-emphasis In FM Set Circuits
Video Amplifiers, D-C Restorers
Simple Wattmeter

OCTOBER 1948

Projection TV
Distributed Capacitance
TV Picture Tubes
High Voltage Test Probes

a TV set operating at peak efficiency, servicemen are going to have a prosperous time.

Mar. 14, New York. Local dealers and several set manufacturers are up in arms because of Zenith's newspaper advertising which is questionable, to say the least, and which can't do either the industry or Zenith a bit of good. Zenith is claiming that "expected changes in wavelengths will not obsolete Zenith TV sets." This sort of bunkum makes the wary public feel that frequency changes are imminent, a fact not supported by FCC in any manner whatever. And, what Zenith fails to mention is the fact that were frequency changes made, it would cost the set owner just about as much to re-adjust a Zenith set as it would to convert other brands. In my opinion Zenith would abet the sale of TV, and particularly their own brand, by sticking more closely to orthodox sales methods. I never did quite approve of Zenith's exceptionally broad claims for their own pet TV idea called Phonevision, (a TV program over the telephone wire for a special service fee), and now it's pretty certain that Phonevision is merely a pipe-dream that will never become reality because the Telephone Company discounts it and publicly admits that Phonevision will not be made available for an indefinite time, if ever.

ANSWERS TO TV QUIZ

[from page 23]

1. (d) Since American television is standardized at 525 horizontal lines per second, with interlaced scanning of 30 frames per second, it takes the product of those two values to determine the total number of horizontal lines scanned per second.

2. (d) While it is true the C-R tube has a certain beam-deflection sensitivity, still, the tube is not classed as an amplifier, hence contains no amplification factor ($u = G_m R_p$). It should rather be considered the C-R tube is a device to convert the video signal into light to make the picture visible.

3. (c) The Control Grid, inserted between the cathode and positively charged anode, is in the form of a negatively charged cylinder surrounding the cathode. Variation of the control grid by the knob on the face of the cabinet (Brightness, etc. Control) controls the actual quantity of electrons permitted into the beam, thus controlling the brilliancy of the pattern finally formed on the screen.

4. (f) Control grid bias, when made

RADIO SERVICE DEALER MAGAZINE

342 MADISON AVE., NEW YORK 17, N. Y.

Please send me the back numbers checked here . . .

The price is 35c. for each copy unless 10 or more are ordered. If 10 or more are ordered the price is 25c. each copy.

<input type="checkbox"/> Jan. 1946	<input type="checkbox"/> Dec. 1946	<input type="checkbox"/> Oct. 1947	<input type="checkbox"/> June 1948
<input type="checkbox"/> Feb. 1946	<input type="checkbox"/> Feb. 1947	<input type="checkbox"/> Nov. 1947	<input type="checkbox"/> July 1948
<input type="checkbox"/> Apr. 1946	<input type="checkbox"/> Mar. 1947	<input type="checkbox"/> Dec. 1947	<input type="checkbox"/> Sept. 1948
<input type="checkbox"/> June 1946	<input type="checkbox"/> May 1947	<input type="checkbox"/> Jan. 1948	<input type="checkbox"/> Oct. 1948
<input type="checkbox"/> July 1946	<input type="checkbox"/> June 1947	<input type="checkbox"/> Feb. 1948	
<input type="checkbox"/> Aug. 1946	<input type="checkbox"/> July 1947	<input type="checkbox"/> Mar. 1948	
<input type="checkbox"/> Sept. 1946	<input type="checkbox"/> Aug. 1947	<input type="checkbox"/> Apr. 1948	
<input type="checkbox"/> Nov. 1946	<input type="checkbox"/> Sept. 1947	<input type="checkbox"/> May 1948	

I remit herewith \$..... for thecopies ordered atc. each.

NAME

ADDRESS

CITY ZONE STATE

sufficiently negative with respect to cathode will completely blank out the beam, rendering the screen dark.

5. (a) By causing a cross-over point (as may readily be seen by examining Fig. 1) the control grid acts as first element in the electronic lens system which controls focus of the beam, permitting it to terminate in a definite spot where it may be scanned and modulated to provide a clean picture. (It should be pointed out that the control grid is a convenient point for inserting video modulation voltage, and is, in fact, so universally utilized.)

HIGH FIDELITY

[from page 21]

TRF Circuits

The old TRF circuit is still probably the best high fidelity circuit for AM. Receivers of this type may be assembled from commercial kits (see Fig. 1) and wired quite economically in the spare time that usually goes to waste. If you have an awful lot of time, four gang condensers and coils may be shopped for on the market at bargain prices. The remainder of the component parts are standard and are stocked in every good service shop.

Imagine having one of these units in your shop on a chassis. Play for the discriminating listener who wants something really good any of the standard five tube radios now on the market and which you have for sale and then play this TRF circuit. Let the customer hear for himself the difference in quality. If he wants the manufactured job, sell it to him; but if he likes the TRF chassis you built up yourself, you are really in business.

Remember this was made in spare time that might have been wasted; it was built from parts bought at your serviceman's discounts; it contains the best components available on the market. You will really be selling quality to quality minded customers. You don't have to sell at too high a price either.

Also, play the receiver with the ordinary built in aerial and then play it with a good type outdoor aerial. If the customer decides that he wants that kind of reception then you have an aerial installation to make. Very few radio receivers today are equipped with aerials of sufficiently good type to give the high quality signal reception most desirable. Antennae are important for all radio receivers, not just for television.

Why do we suggest the TRF circuit? Simply because you can get the

best in high fidelity today only with a properly designed TRF on the AM band. Anybody who wants that kind of high fidelity will have to get it from someone who will custom build it for him. Who can better do that than the man who works with all kinds of circuits daily and sees all kinds of part layouts, wiring arrangements, etc. He has a background of experiential know-how that is wasted if he is simply a tube changer or a condenser replacer.

However, let me remind you that in a good radio receiver of the high-fidelity type there must be high fidel-

ity all the way through. This must include the antenna, every stage of the receiver, the amplifier, the power supply system, and the loudspeaker. Failure to observe high fidelity requirements at any stage will reduce the quality of the reception, the tone and the response range at the speaker. High fidelity is a case of all or nothing at all. This, I suspect, is why we have so little true high fidelity in radio reception at prices the average man can afford to pay. It is not possible to shave a little here or cut a corner there and fool the electrons. These scientific entities are not sus-

12 WAYS

TO CUT CONTROL INVENTORIES

You can reduce your stock of replacement controls, and profit in time and money with these 12 IRC Tap-In Shafts. IRC engineered for easy installation and dependable performance with IRC Tap-In Shaft Controls, they cut both service time and costly stocks of exact duplicates.

Accurately tapered sockets in IRC Tap-In Shaft Controls readily receive the closely machined shaft ends. A firm hammer tap permanently 'freezes' the two units. 'C' washers and other cumbersome locking arrangements are entirely eliminated. IRC Tap-In Shafts are quick, easy . . . and secure!

IRC Tap-In Shafts can be conveniently cut to desired lengths before being installed. In crowded chassis, they can be installed *after* control is assembled—eliminating any necessity to remove other parts.

There's an IRC Tap-In Shaft for most radio and television requirements. Used with IRC Tap-In Shaft Controls, you are sure of smooth, quiet, trouble-free service. Ask your distributor for IRC Controls—with the *dependable* Tap-In Shaft feature. International Resistance Company, 401 N. Broad Street, Philadelphia 8, Pa. In Canada: International Resistance Co., Ltd., Toronto, Licensee.

INTERNATIONAL RESISTANCE CO.

Whenever the Circuit Says 

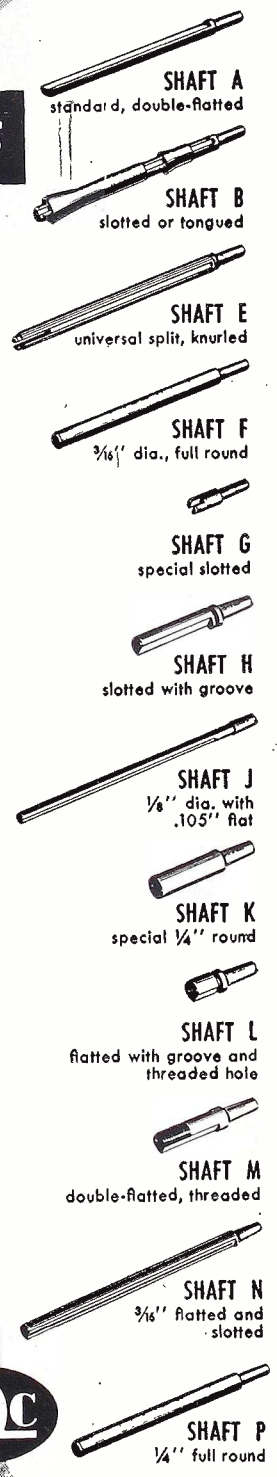

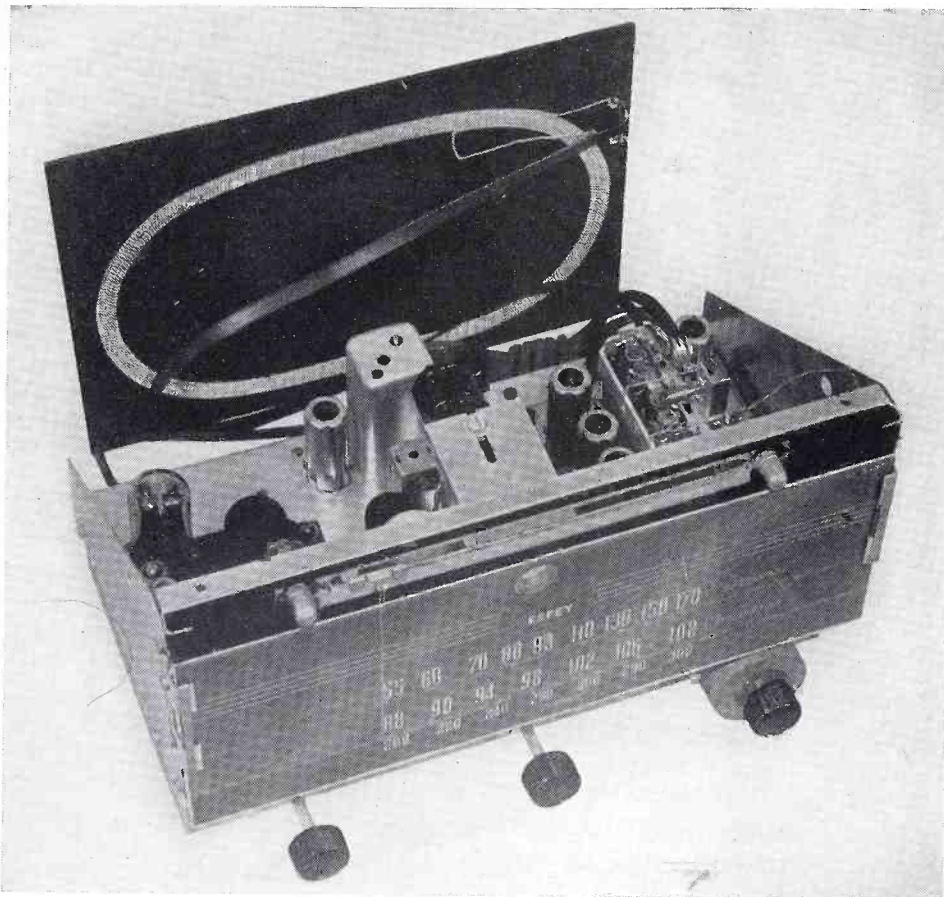

Fig. 2—Typical commercial Super-Het tuner by Espey.

ceptible to the honey of the promised land psychology of the advertiser. While paper will not refuse ink, the electrons will refuse to produce high fidelity unless high fidelity has been written into every jot of the entire circuit. *Caveat emptor.*

The Superhet

High fidelity is also achievable with

the superhet, but there must of necessity be great care taken in the layout of component parts, the dressing of grid and plate leads, and the use of shielding for noise reduction. For the utmost in high fidelity with the superhet the following specifications are worthy of more than casual attention:

1. A properly installed antenna of the Marconi type with a twisted pair lead-in will give the highest signal to noise ratio.

2. Include at least one r-f stage for reduction in noise level and improvement of the automatic volume control, and elimination of some of the image frequency common to the superhet circuit.

3. Install a separate oscillator tube to cut down tube noise common to the mixer converter dual purpose tubes. The separate oscillator stage will improve signal gain and stabilize the oscillator.

4. Include a separate tube as the mixer. Arrange the circuit so that the i-f frequency is 455 kc below the incoming signal frequency. This improves signal gain, cuts down image frequency "birdie" whistles, and feeds a relatively pure signal on to the i-f amplifiers.

5. Include at least two, but preferably three, stages of i-f amplification. Use only the highest quality i-f transformers made by some top quality coil manufacturer.

6. The detector and first audio stage may be combined in one tube, but for the utmost in high fidelity use a separate detector and a separate first audio stage.

All bypass and coupling condensers should be of silver mica or mica types. These will never break down in service. The resistors should be of high quality carbon composition in the standard 10% tolerances. One of the defects in many commercial receivers today is the poor quality composition resistors and the cheap paper condensers. Avoid these like the plague for the custom built high fidelity receivers. It will pay you ever so much more in the long run. Fig. 2 shows a typical high fidelity superheterodyne chassis for those who prefer not to build this unit.

**SERVICEMEN
DEALERS**

**BUILD YOUR RADIO SALES
AROUND THIS *Quality*
CHASSIS**

**NEW
MODEL 511
ESPEY
CUSTOM BUILT
RADIO**

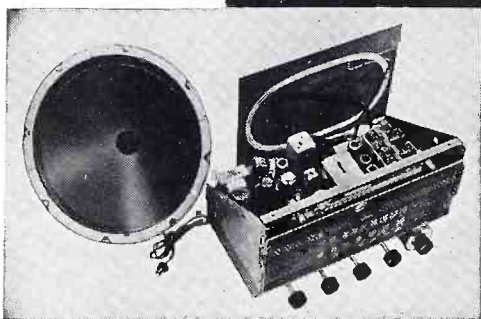

This profitable chassis replacement market means increased sales to you and increased savings to over 19 million potential customers.

• Here is a fine radio, in chassis form, to please the most discriminating music lovers.

• Easy to install in any console cabinet old or new, the Espey 511 AM-FM radio chassis embodies the latest engineering refinements for lasting high quality at a price that defies competition.

• Features, 12 tubes plus rectifier and tuning indicator; drift compensated circuit for high frequency stability; tuned RF on AM and FM, high fidelity push-pull audio; 13 watts power output; wide range 12" PM speaker; smooth flywheel tuning; phono input provision; separate AM and FM antennas.

Sold through your favorite parts distributor.

Write for catalogue D1 containing complete specifications.

ESPEY Makers of fine radios since 1928.
MANUFACTURING COMPANY INC.
528 EAST 72nd STREET, NEW YORK 21, N. Y. • TEL. BUtterfield 8-2300

SIG. GEN. DESIGN

[from page 18]

at the high end of P_1 we must have .01 volt available at the first switch position.

The actual mathematics involved in the voltage division computation are rather involved, as we must take into consideration source regulation, and voltage step-up when switching the terminal box load associated with the center tap of S_2 . From a functional standpoint if the meter M is set to .1 volt the voltage applied to the attenuator is .01 or 10,000 microvolts. By selecting the next three positions of

S_3 we have the ability of dropping this output as seen by the terminal load in steps of 10. We therefore have a choice of 10,000-1000-100-or 10 microvolts out to the terminal box depending upon the setting of S_3 . We further have the ability of changing the voltage input by the vernier microvolt control P_1 from 0 to unity voltage applied. Simply, this means that we can read on the meter directly the voltage applied, and divide and vernier control the voltage output from 0 to 10,000 microvolts.

There is an additional panel control to consider. This is the potentiometer P_2 , which is an oscillator plate potential control. This potentiometer determines the amount of voltage applied to the plate of the oscillator, and in turn the amount of r-f output. We can set the r-f output of the oscillator anywhere from 0 to 1 volt as read by the voltmeter circuit, by adjustment of this panel control. If we set the oscillator output to read .1 volt on the output level meter, we have available at the terminal box the completely controllable range of between 0 and 10,000 microvolts. If we adjust the potentiometer P_2 so that the meter reads 1 volt we have available at the terminal box the controlled range of 0 to 100,000 microvolts. If we require the range of between 0 and 1 volt we simply take the output from the high output jack associated with P_1 and use the microvolt control (P_1) to vary the output level against its directly calibrated scale. This means that we have at our control the entire output level from 0 to 1 volt directly metered and calibrated. Although this explanation may seem rather lengthy, functionally and from a use standpoint it is extremely simple. It serves rather to point out the heart of a real signal generator, and to illustrate the vast differences that exist between an instrument of this type and the simple test oscillator.

Since we have shown that the goodness of a real signal generator is fundamentally the accuracy of its output level, you may well ask why we impose upon the end user the rather insignificant bother of changing his output connections from the terminal box to the high output jack when working in the range between 100,000 microvolts and 1 volt.

Maintaining Constant Frequency

Model 906 was designed essentially to be a serviceman's tool. Since a certain price had to be maintained, the product could not incorporate triple mechanical/electrical shielding and stay within the normal service-

Success! IT'S HERE!



TRICRAFT VIDEO ANTENNA
for
Indoor Use

Model "600"

Patents Applied for

The indoor model television antenna the industry has needed!

- Appearance
- Operation Principle
- Simplicity
- Reception

Here is the new VIDEO ANTENNA you've been waiting for... new luxurious appearance which blends with any type furnishings... new design and operation, no mechanical adjustments to change stations, turn switch to channel desired, electrically tuned to station... good reception for as far as 25 miles, 1 to 1.5 standing wave ratio in each channel... easy to use, instantly ready for use... operates anywhere in the house, no landlord's permission needed... net weight only 3 3/4 lbs.

"Tricraft" antennas are available at leading jobbers. If your jobber cannot supply you, write us for nearest jobber.



Tricraft Products Co.

1539 North Ashland Ave., Chicago 22, Ill.

Manufacturers of complete line of Television, FM and AM antennas and accessories

We'll be there Again...



with a few NEW "TRICKS" for the trade

• Yes sir, we've learned so many new tricks the past year we're beginning to feel like magicians. What's more, we're not at all touchy about being asked how they work. Just stop by at the Show and we'll go into our act. We're anxious for you to know how welcome you'll be and have even considered laying out an Astatic second vice president as a welcome mat. Won't you help us set a new boxoffice record for handshakes?



SEE US AT
BOOTH 141
RADIO PARTS
AND
ELECTRONIC
EQUIPMENT
CONFERENCE
AND SHOW
STEVENS HOTEL,
CHICAGO

MAY 16 to 20

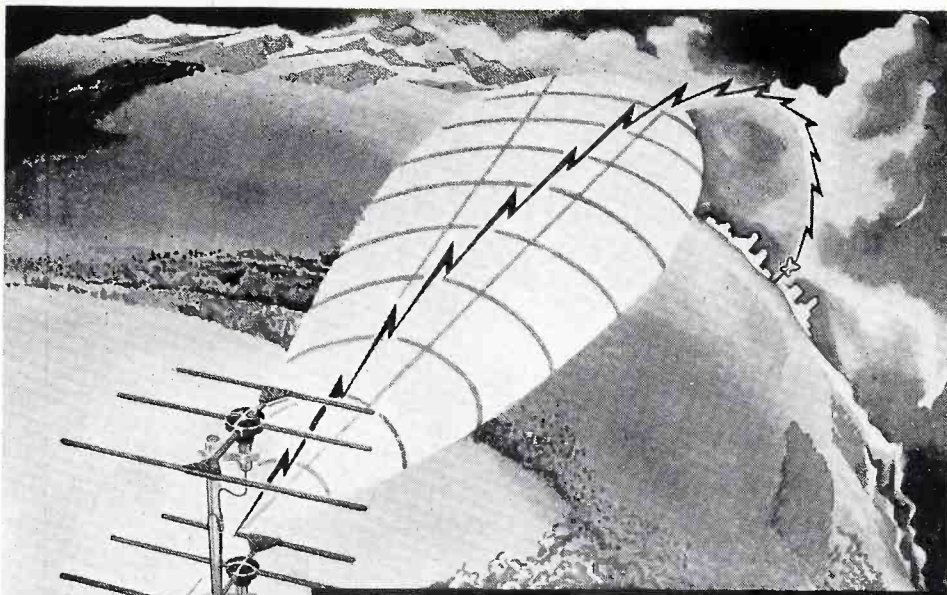

TELEVISION RECEPTION PROBLEM — No. 2 of a series.

WORKSHOP TV ANTENNAS REDUCE CO-CHANNEL INTERFERENCE AND NOISE TO A MINIMUM

The very sharp directional pattern of Workshop's Super High Gain 6-Element Array combined with its high "front-to-back ratio" cut interference so that fringe areas enjoy sharp, brilliant reception.

INTERFERING
CO-CHANNEL
SIGNAL

Send for the new Workshop TV Catalog (No. 49)

THE WORKSHOP ASSOCIATES, Inc.

Specialists in High-Frequency Antennas

69 NEEDHAM STREET, NEWTON HIGHLANDS 61, MASSACHUSETTS



man's purchasing range. Means there-
fore had to be devised to circum-
vent certain engineering problems, to
keep this instrument at a predeter-
mined price level. The obvious solu-
tion was to directly control the out-
put level of the oscillator by varying
anode potential. In any oscillator,
when plate voltage is changed it is the
same thing as changing the load. This
of course means that the fundamental
frequency of the oscillator must also
change. The rather novel circuit em-
ployed in 906 allows direct oscillator
plate potential changes of between 0
to 180 volts with negligible frequency
shift. Such shift is controlled by the
special "loaded" circuit and band
switch coil employed for each range.

Since stray radiation which would
invalidate the goodness of the attenua-
tor system can be controlled by oscil-
lator potential adjustment we have
benefited ourselves some 100 times.
This is computed by the square of the
voltage ratios mentioned. Radiation
directly from the oscillator circuit
may, therefore, be held very close to
0; due to low level output and two
mechanical/electrical shields employed
in this unit's housing.

One other source of stray radiation
must also be eliminated. The end of
the reactive load (L_4) even if it were
by-passed is capable of developing r-f
potential in the power supply. This
represents a high impedance looking
from the generator source back to
the power supply and is adequately
by-passed by the series r-f load C_{5a} ,
 C_{10a} , P_1 . Since some small r-f poten-
tial is capable of being developed
back through the power supply and
a-c line, some means must be em-
ployed to stop this unwanted voltage.
The combination filter network L_1 -
 L_{1c} , and associated by-pass network,
effectively stops line coupling throug-
hout the entire range of 906.

Power Supply

The power supply in Model 906 is
conventional. To minimize the posi-
bility of 120 cycle modulation a triple
filter network is employed. Such filtra-
tion insures good clean d.c. to all cir-
cuits, and is essential to high quality
performance of the audio and FM cir-
cuits.

Modulation

Looking at the lower portion of the
schematic (Fig. 2), we see the audio
(AM) modulating circuit. The audio
oscillator is of the wien bridge type
whose frequency is exactly 400 cycles.
The balanced bridge in the grid/cath-
ode circuit of the 6AU6 is the fre-
quency determining network, with the
lamp S_6 performing the function of
a degenerative or stabilizing element.

The Meissner 9-1091-C AM-FM Tuner

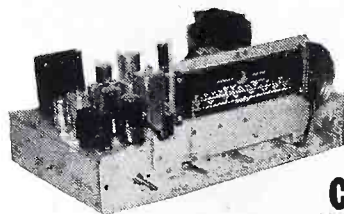

THE IDEAL COMPONENT
FOR CUSTOM INSTALLATIONS

COMBINES FIDELITY WITH STABILITY

Servicemen and others interested in custom installations will be quick to appreciate the many top features of the MEISSNER 9-1091-C AM-FM Tuner.

Here is real quality—precision workmanship—outstanding design, all combined to give you the very highest fidelity reception and at remarkably low price.

Frequency response—sensitivity both are phenomenal! Compare the specifications below and your choice will be the MEISSNER 9-1091-C Tuner.

MEISSNER is designing a high fidelity amplifier for this tuner. Watch for the release announcement.

See The 9-1091-C Tuner At Your Jobber
Or Write For New Meissner Catalog

Features

- Frequency Response flat with plus or minus 2 db 30 to 15,000 cycles
- Bass Control provides 10 db boost at 40 cycles
- Treble suppression of 12 db at 8,000 cycles
- Input Jack for Crystal or high level magnetic type phono pickup
- Sensitivity less than 10 microvolts
- "Broad" or "sharp" selectivity for AM
- Hum level 60 db below full output
- Output 11 volts high imp. terminals, 2 volts on 500 ohm terminals
- 300 ohm FM antenna input. FM antenna and line act as efficient AM antenna

MEISSNER

MEISSNER MANUFACTURING DIVISION
Maguire Industries, Inc., Mt. Carmel, Illinois

HIGH-VOLTAGE

PAPER

TUBULARS

for TELEVISION,

OSCILLOGRAPHS, etc.

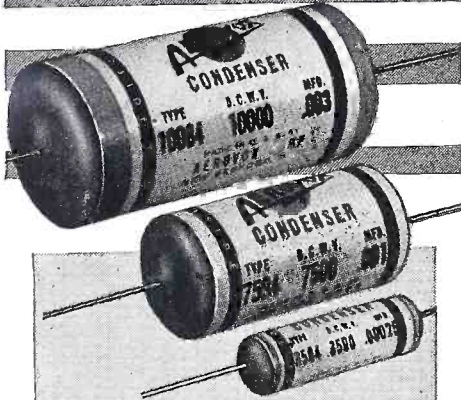

• Interested in higher-voltage, dependable yet inexpensive paper capacitors? Here's the Aerovox answer:

The popular Aerovox Type "84" paper tubulars are now available in extended-voltage ratings—2500, 3500, 5000, 7500 and 10,000 volts D. C. W. Capacitances of .0001 to .05 mfd. Compact dimensions—from 3/8" dia. by 1-1/2" long for smallest, to 1-3/8" dia. to 3" long for largest. Oil-impregnated wax-filled. Sturdy insulating tube. Sealed ends. Bare pigtail leads that won't work loose. Bright yellow-red-black label jacket. And tough!

• See Our Jobber...

These extended-voltage paper tubulars are now available. Order your needs from our jobber. Ask for latest catalog.



FOR RADIO ELECTRONIC AND INDUSTRIAL APPLICATIONS

AEROVOX CORP., NEW BEDFORD, MASS., U.S.A.
 Export: 13 E. 40th St., New York 16, N.Y. • Cable: 'ARLAB'
 In Canada: AEROVOX CANADA LTD., Hamilton, Ont

The actual oscillator consists of the 6AU6, and the first 6C4. The output of the first 6C4 has a load circuit shunted by the audio output control P_3 . The setting of this control determines the amount of audio grid drive applied to the second 6C4 modulator tube, and thus the percentage of modulation. AM modulation of the r-f oscillator is accomplished by the tried and true Heising method, with the audio choke L_5 acting at the common load. Modulation percentage of the r-f oscillator may be varied from 0-30% when the output level indicator is in the 1 volt position. When the r-f output is .1 volt modulation capabilities are from 0 to over 100%. This is again directly calibrated on a scale associated with this control.

The other necessary function of any modern signal generator is that of a frequency modulated output as previously mentioned. In Model 906 this is accomplished by the circuits indicated as 6C4 and 6AU6 located directly above the audio oscillator (Fig. 1). The 6C4 is employed as a three terminal oscillator with a center frequency of 40 mc. Across a portion of the resonant r-f plate load is shunted the reactance modulator, (6AU6). The reactance modulator (6AU6) although a pentode is triode connected to raise its effective transconductance for this application. The phase shift network consists of the air trimmer C_{2a} (plus C_{psg}) and the carbon resistor R_{4b} . At this frequency it is possible to obtain a little better than 1300 kc. of total swing, or frequency modulated output. Such frequency excursion is directly controlled by P_3 which is switched to serve as a sweep control for FM work. The grid excitation or modulating voltage is obtained via the voltage dividing network R_{8a} , R_{10e} , tapped directly off the secondary of the power transformer. In the FM switch position the plate potential is removed from the AM audio oscillator, and such voltage applied to the FM circuits.

The method of mixing the variable r-f and fixed FM oscillators is also novel. These units are physically located so that the r-f field of either will modulate the other oscillator grid. We therefore have a mixer circuit that is completely effective without employing a separate mixer tube. The sum or difference frequencies (usable FM output) are available through the attenuator network or high output jack previously described.

Characteristics

It was mentioned that on the highest band in 906 we purposely employ second harmonic insertion. When we

Everybody agrees
ATR VIBRATORS
 are TOPS!

ATR



AUTO RADIO VIBRATORS

have Ceramic Stack Spacers

Visit ATR Booth
 82 Radio Parts
 Show May 16 to
 20 Chicago

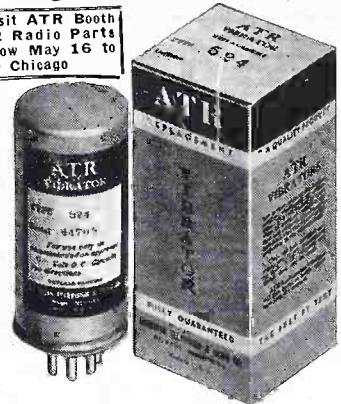

A COMPLETE LINE OF VIBRATORS...

Designed for Use in Standard Vibrator-Operated Auto Radio Receivers. Built with Precision Construction, featuring Ceramic Stack Spacers for Longer Lasting Life.

Backed by more than 17 years of experience in Vibrator Design, Development, and Manufacturing.

ATR PIONEERED IN THE VIBRATOR FIELD.

NEW VIBRATOR GUIDE FREE



ATR

"A" BATTERY ELIMINATORS

for DEMONSTRATING AND TESTING AUTO RADIOS

New Models... Designed for testing D. C. Electrical Apparatus on Regular A. C. Lines. Equipped with Full-Wave Dry Disc Type Rectifier, Assuring Noiseless, Interference-Free Operation and Extreme Long Life and Reliability.

NEW DESIGNS
 NEW MODELS
 NEW LITERATURE
 ATR "A" Battery Eliminator, DC-AC Inverters, Auto Radio Vibrators
 See your jobber or write factory

AMERICAN TELEVISION & RADIO Co.
 Quality Products Since 1931
 SAINT PAUL 1, MINNESOTA-U.S.A.

consider the rising controlled stray radiation a practical limit is reached at roughly 60 mc. The last frequency range operates at $\frac{1}{2} F$, both in the

interest of fundamental oscillator stability, and the need for accurate attenuation or output voltage division throughout this high frequency range.

The amount of second harmonic content is essentially a product of the short grid excitation cycle, the L/C ratio, and circuit conformation. This relationship has been very carefully computed to allow proper reading of the voltmeter circuit throughout this highest frequency range.

To sum up the essential characteristics and practical specifications of this unit, the following is pertinent. Basic frequency range unmodulated completely controllable from 0 to 1 volt, is 90 kc to 170 mc. The FM frequency range is from 0 to 210 mc by utilizing the sum and difference mixed output. Modulation (AM) is from 0 to over 100% at 400 cycles. Controlled FM swing or sweep is at a 120 cycle rate adjustable from 0 to 1300 kc.

Essentially, we have described a piece of equipment designed to meet a current need throughout the ranks of service technicians. The problems of radio servicing have become very complex due to establishment of new broadcasting techniques, and the necessary different receiving and transmitting apparatus. To cope with these problems the progressive technician must have a signal generator of the type described or a comparable unit. The day of the simple test oscillator is over; the day of the signal generator and of precision test equipment is very definitely with us. The wise service establishment must be equipped to handle these complex problems if it desires to operate and prosper in the modern service market.

TV TEST EQUIPMENT

[from page 16]

(at 2.5 mc) is operating in addition to the variable frequency oscillator. In the .25 mc position, the crystal oscillator (at .25 mc) is operating in addition to the variable frequency oscillator and the 2.5 mc oscillator as well.

6. *Range.* This control is a band-switching arrangement for the variable frequency oscillator.

7. *RF Out Connector.* This connector makes available the output from the variable frequency oscillator to a shielded cable.

8. *RF In.* This binding post may be used to apply an external r-f signal when the calibrator is used as a heterodyne frequency meter.

9. *Phones Jack.* Ear phones may be used in this jack, rather than the speaker, where a very small input signal is available.

10. *Ground Jack.* This binding post is used as the common ground terminal for all test equipment associated with this calibrator.

Insure BETTER Television Service to Your Customers! . . . Exclusively Designed

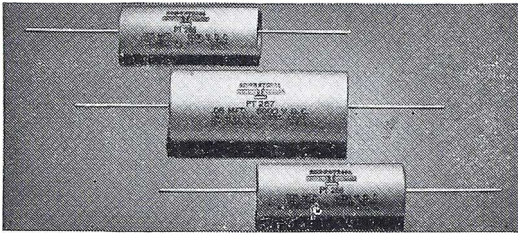

HIGH VOLTAGE AND ELECTROLYTIC TUBULAR TELEVISION CAPACITORS



Especially Engineered for Television Circuits by INDUSTRIAL CONDENSER CORP.

The economical quality line for replacement. Industrial Condenser Corp., manufacturers of Capacitors exclusively brings you highest quality for the particular requirements of Television at exceptionally attractive prices! Special Capacitors are Pyroteen impregnated for low power factor, high insulation resistance, high operating temperatures. Oil, Pyroteen, Wax and Electrolytic Capacitors. Finest materials throughout.

Ask Your Jobber for our Attractive Prices Today!

Or write for Bulletin 1095. Industrial makes quality Capacitors for Television, Radio, every electronic and industrial application—all types.

Send for Complete Catalog

INDUSTRIAL CONDENSER CORP.

N. CALIFORNIA AVENUE CHICAGO 18, ILLINOIS
Sales offices in all principal cities

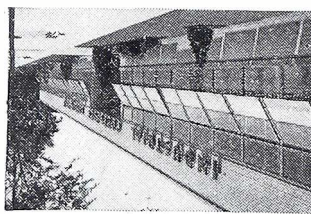

Modern plant built by Industrial Condenser Corp., for manufacture of capacitors only.

FOR ALL TV CHANNELS

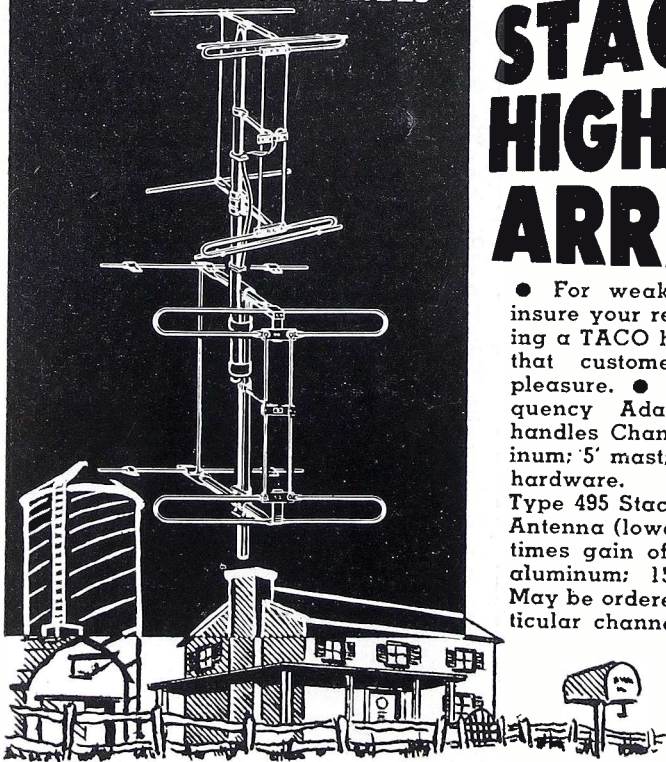

STACKED HIGH-GAIN ARRAYS

- For weak TV signal areas, insure your reputation by installing a TACO high-gain job to give that customer more watching pleasure. • Type 444 High-Frequency Adapter (upper unit) handles Channels 7-13. All-aluminum; 5' mast; matching network; hardware.
- Type 495 Stacked Low-Frequency Antenna (lower unit) provides $3\frac{1}{2}$ times gain of single dipole. All-aluminum; 15' mast; hardware. May be ordered tuned to any particular channel.

Ask our jobber to show you these TACO kits.
Catalog on request.

TACO

RADIO & ELECTRONIC EQUIPMENT
TECHNICAL APPLIANCE CORP.
SHERBURNE, N. Y.

IN CANADA: STROMBERG-CARLSON CO., LTD., TORONTO 4, ONT.

Camco

TV and FM ANTENNAS (Swift-Rig)

Directional High Gain and Half-Wave arrays

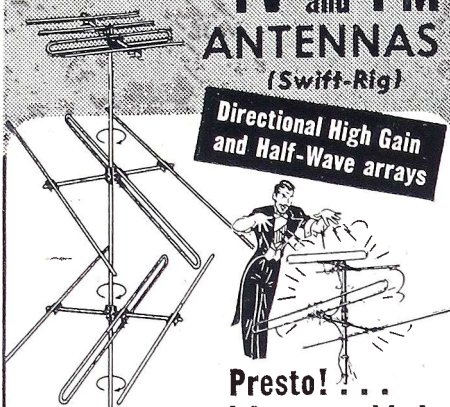

Presto! . . . it's assembled

"Swift-Rig" antennas are completely assembled — Just Unfold and Lock in Place . . . A matter of minutes.

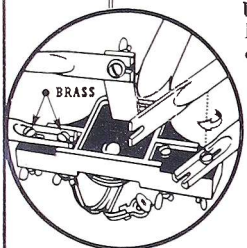

One of the leading lines of TV and FM Antennas and Accessories Made.

Outstanding Features

- PERMANENT LOW RESISTANCE . . . nickel plated brass screws and "SWIFT RIG" LUGS at electrical contacts
- SEPARATE STACKED ARRAYS . . . Directional High Gain antennas for each band of frequencies

Send for catalog showing complete Camco line of antennas and accessories including Roto-Matic Window and Hy-Gain Indoor Antennas, Combination Screw Eyes for 300 ohm line and coaxial cable, Mast-Mounting brackets (chimney, vent pipe, wall-mount), "Swift-Rig" Lugs, etc.

CAMBURN • INC.

32-40 57th St., Woodside, L. I., N. Y.

Some Sales Territories Available

\$1.00 to \$5.00 PAID for "SHOP NOTES"

Write up any "kinks" or "tricks-of-the-trade" in radio servicing that you have discovered. We will pay from \$1 to \$5 for such previously unpublished "SHOP NOTES" found acceptable. Send your data to "Shop Notes Editor," RADIO SERVICE DEALER, 342 Madison Ave., New York 17, N. Y. Unused manuscripts cannot be returned unless accompanied by stamped and addressed return envelope.

The WR 39-A functions as a marker-generator and is designed to produce the frequencies specified. All of the standard RMA Television frequencies, (sound and picture carrier, sound and picture IF, and local oscillator frequencies) are harmonics of .25 mc, the fundamental crystal frequency. Thus, by the very nature of this instrument and its calibration the service man may easily identify any particular frequency.

As is the procedure with any marker-generator the signal is coupled into the circuit under test which also has applied a wide band sweep frequency generator signal. Visual alignment, employing an oscilloscope, is rapid and accurate in competent hands and is fast supplanting the old point-to-point method of alignment. While this Calibrator is unusually versatile and can be used as a signal generator, (with or without modulation) for adjusting FM receivers or television traps, and for signal injection, its primary purpose lies in its use in visual alignment of television wide-band amplifiers.

To operate this unit, the power is connected, the output cable is placed in the RF Out connector, and the Volume is turned on. The unit is allowed to warm up for a short period of time before calibration. To calibrate, the RF Out control is turned off and the Calibrate control is turned to 0.25 mc which means that both the 0.25 mc crystal oscillator and the 2.5 mc crystal oscillator are turned on, as well as the variable-frequency oscillator. Turn the Crystal Adjust control and listen for a low-frequency note in the speaker, which is the beat between the 2.5 mc crystal standard and the tenth harmonic of the 0.25 mc crystal oscillator.

Zero beat will be the point where the 0.25 mc oscillator's tenth harmonic is exactly 2.5 mc. If there seems to be a slight range of adjustment through zero beat, set the control halfway between these extremes. The WR-39A is now ready for use as a marker generator or heterodyne frequency meter, with an accuracy of 0.01%.

The variable-frequency oscillator may be calibrated through the use of these two crystal oscillators by choosing a given point on the dial and noting the calibration of this point in relation to the crystal oscillators. Assume that a frequency of 83.25 mc (channel 6 picture carrier) is desired as a marker. Turn the Range switch to D position, the Calibrate switch to 2.5 mc and rotate the Tuning control, noting the zero beats at every 2.5 mc. Referring back to the func-

which of these costly 6 HANDICAPS slows up your soldering?

- Frequent Retinning and Redressing?
- Delayed heating? Clumsy, rigid tip?
- Obsolete source of heat?
- Blind spots? Awkwardly shaped iron?

NEW WELLER SOLDERING GUNS Eliminate Them All!

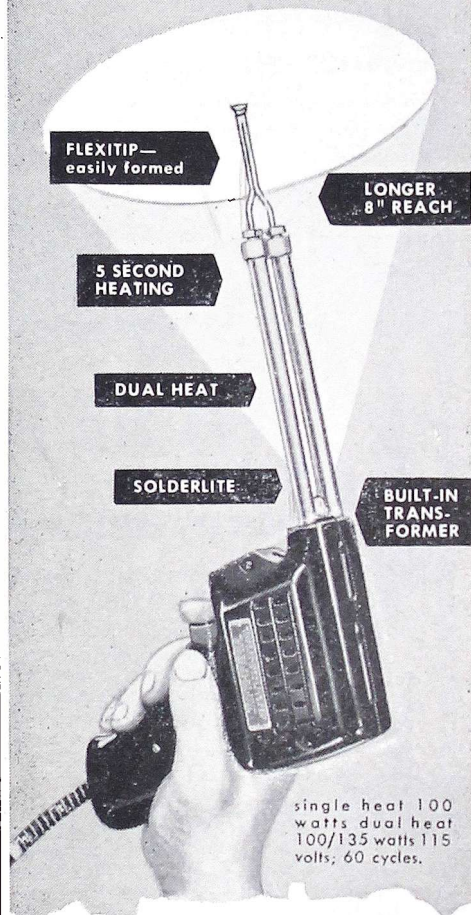

single heat 100 watts, dual heat 100/135 watts 115 volts, 60 cycles.

Five-second heating saves time. Quickly formed FLEXITIPS slip easily between wiring. Prefocused Solderlite spotlights your work. And because heat comes "on" only when you pull the trigger, there's no over-heating—no unnecessary retinning or redressing with genuine Weller tips. Your Weller Gun pays for itself in a few months.

For all radio, television and appliance service work, use efficient 8" model DX-8 with dual heat, or 4" types—S-107 single heat or D-207 dual heat. Order from your distributor or write for bulletin direct.



Be sure to get your copy . . . **SOLDERING TIPS**, the new Weller Handy Guide to easier, faster soldering—20 pages fully illustrated. Price 10c at your distributor's, or order direct.

WELLER

MANUFACTURING COMPANY
804 Packer Street • Easton, Pa.

TITONE

Now! A \$10 SALE

for every record-player in your area!

LIST PRICE \$7.50

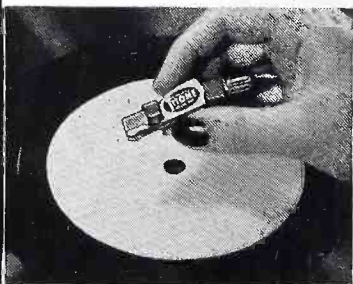

SELL NEW TITONE PICKUP to every customer!

Here's a way to quick profit from every player owner who visits your shop! Have your salesmen "plug" it on every service call! First basic pick-up advance in over 10 years—the original piezoelectric ceramic pickup, made by SONOTONE, famous makers of hearing aids and miniature tubes!

- SELLS ITSELF IN A 2-TO-5-MINUTE CALL! Fits all tone arms. Let all your customers hear TITONE. They'll say "SOLD!" because—
- TRANSCRIPTION TONE QUALITY! Full frequency to 10,000 cycles! Real high fidelity! Bell-like supertone makes even old players thrilling!
- SURE-FIRE IN HUMID CLIMATES! Utterly unaffected by climate, moisture, fungus! Booms sales, wins back customers.
- DOUBLES RECORD LIFE AND PLEASURE! Gives "ordinary" records sparkling quality—revives worn favorites. Will play down to 1/2 normal pressure. NO "needle talk"!
- RUGGED! PERMANENT! No crystals, magnets, filaments to fail! No pre-amplifiers. Ceramic TITONE performs perfectly for years!

NO TONE LIKE TITONE
CALL YOUR JOBBER—
 or write now to
 SONOTONE, Box T-3, Elmsford, N. Y.

picks up profit NOW!

tions of the controls the 2.5 mc position of the Calibrate control will be seen to mean the 2.5 mc crystal oscillator and the variable frequency oscillator are on at the same time. A beat note is noticed at 82.5 mc and also at 85.0 mc, which is on either side of the desired frequency of 83.25. Rotate the Tuning control to precise zero beat at 82.5 mc even though the dial does *not* indicate exactly 82.5 mc. Turn the Calibrate switch to 0.25 mc (which means all three oscillators are working) and slowly adjust Tuning toward a higher frequency. There will now be a beat at every 0.25 mc and three beats up the scale from 82.5 mc will be 83.25 mc. This procedure requires a little practice, but a very precise frequency marker will be obtained.

AD INDEX

Aerovox Corporation, The.....	45
Alliance Manufacturing Co.....	8
American Television & Radio Co.....	45
Astatic Corporation, The.....	43
Brach Mfg. Corp., L. S.....	35
Camburn Inc.	47
Coastwise Electronics Co.....	37
Espey Mfg. Co., Inc.....	42
Federal Tel. & Radio Co., Inc.....	3
General Electric Co. (Components).....	33
General Electric Co. (KenRad Div.)	5
General Electric Co. (Tube Div.).....	13
General Industries Co., The.....	36
Halldorson Co., The.....	38
Hytron Radio & Electronics Corp.....	14
Industrial Condenser Co.....	46
International Resistance Co.....	41
Ken Rad Div. of G.E. Co.....	5
Mallory & Co., Inc., P.R.....	Cover 2
McMurdo Silver Co., Inc.....	34
Meissner Mfg. Div. Maguire Industries	44
Ohmite Manufacturing Co.....	12
Radiart Corporation, The.....	31
RCA-Victor (Test Equip. Div.).....	7
RCA-Victor (Tube Div.).....	Cover 4
Rider Publisher, Inc., John F.....	11
Shure Brothers, Inc.....	32
Sonotone Corp.	48
Sprague Products Co.....	10
Star Expansion Bolt Co., Inc.....	48
Stewart-Warner Corporation	Cover 3
Sylvania Elec. Products, Inc.....	1
Technical Appliance Corp.....	46
Telrex, Inc.	48
Tricraft Products Co.....	43
U.S. Treasury Dept.....	39
Weller Mfg. Company.....	47
Workshop Associates, Inc., The.....	44

Telrex INC.
CONICAL ANTENNAS
 RUTHERFORD AVENUE ON ROUTE 35
 ASBURY PARK, N. J. PHONE: ASBURY PARK 1 0119
 BOX 879R, ASBURY PARK, N. J.

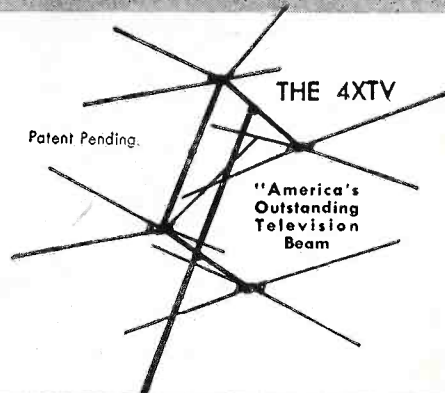

- Hi-Gain Stacked Conical "V" Beam
 - Channels 2 to 13 Plus FM
 - Low Inception Angle
 - Extremely High Signal to Noise Ratio
 - 150 Ohm Non-varying Impedance
 - Use 72, 150 or 300 Ohm Transmission Lines
 - Universal Mounting Clamps
- SEE YOUR DISTRIBUTOR**

Easier Antenna Installations

Star Expansion Bolts make it easy to fasten TV equipment to brick, stone, concrete or any other type of masonry. Help you to position antenna masts, cables and lines in the best possible manner... assure greater satisfaction; reduce service calls. There's a Star fastening for every masonry job. See your jobber or write for details.

★ STAR EXPANSION BOLT CO. INC.
 147 Cedar Street, New York 6, N. Y.

Big Set Performance... IN A JEWEL CASE

Smaller than a telephone— weighs only 3½ lbs.—yet it's a full-power AC-DC radio with a voice like a console! In no sense a toy, Air Pal Sr. is built like a watch, with planetary drive, on-the-dot tuning... built-in Radar Antenna, and PM dynamic speaker. There's nothing like it!

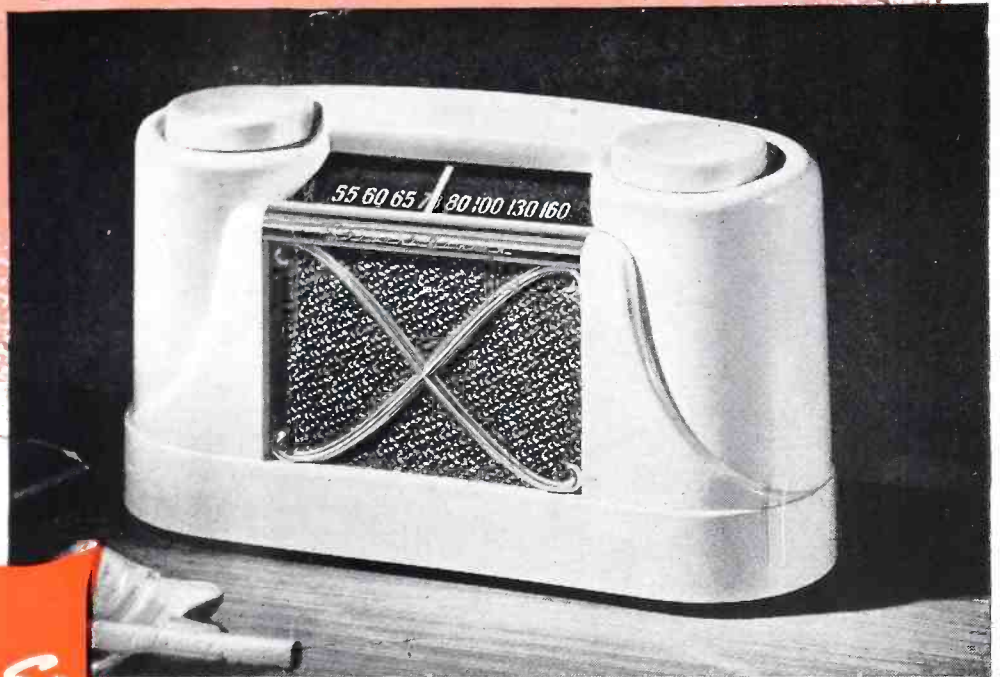

AIR PAL *Sr.*
by
Stewart-Warner

Plays Anywhere You Plug It In!

Railway trains, planes, ships... in hotels, offices, or any room in the house—Air Pal Sr. will perform anywhere it can be plugged in.

\$19.95

CALL YOUR NEAREST Stewart-Warner DISTRIBUTOR TODAY!

ALBANY, N. Y.
Ft. Orange Radio Distrib., Inc.
ALBUQUERQUE
Charles Iffeld Co.
ATLANTA
Cowan-Boze Co., Inc.
BALTIMORE
Baltimore Gas Light Co.
BINGHAMTON, N. Y.
Empire Distributors
BIRMINGHAM
Alabama-Florida Distrib. Co., Inc.
BOISE
Graybar Electric Co.
BUFFALO
Lee Distributing Co.
BUTTE
Treasure State Gas & Electric Co.
CHARLOTTE, N. C.
Shaw Distributing Co.
CHATTANOOGA
Standard Appliances, Inc.
CHICAGO
Remco, Incorporated
CINCINNATI
Harry F. Knodel Distributing Co.
CLEVELAND
Cleveland Distributing Co.
DAVENPORT, IA.
Graybar Electric Co., Inc.
DENVER
Ralph Olsen Sales Co.
DES MOINES
Graybar Electric Co.
DETROIT
Specialties Distributing Co.
DUBUQUE
Diener Appliances

EUGENE, ORE.
Graybar Electric Co.
FARGO, N. D.
Shirley-Onstad, Inc.
FLINT, MICH.
Silkworth Distributing Co.
FT. SMITH, ARK.
Wise Radio Supply
GRAND RAPIDS, MICH.
Graybar Electric Co.
GREAT FALLS, MONT.
Treasure State Gas & Electric Co.
HARTFORD, CONN.
Wood-Alexander & Co.
HOUSTON
Lock's Wholesale Distributors, Inc.
HUNTINGTON, W. VA.
Emmons-Hawkins Hardware Co.
INDIANAPOLIS
McKee Distributing Co., Inc.
JACKSON, MICH.
Silkworth's
JACKSONVILLE, FLA.
L. Luria & Son, Inc.
KANSAS CITY
Fitzgerald & Co.
LAWRENCEVILLE, ILL.
Suttle Equipment Co.
LITTLE ROCK
Connerly Radio Distributors
LONG ISLAND CITY
John W. Walter, Inc.
LOS ANGELES
Sherman-Swenson & Associates
LUBBOCK, TEX.
Anderson-Young Electric Co.
MANKATO, MINN.
So. Minnesota Supply Co.

MEMPHIS
Woodson-Bozeman, Inc.
MIAMI
L. Luria & Son, Inc.
MINNEAPOLIS
Elcon Products, Inc.
MINOT, N. D.
Shirley-Onstad, Inc.
NASHVILLE
Southeastern Appliance Dist. Co.
NEWARK, O.
William's Wholesale Distributors
NEWBURGH, N. Y.
Newburgh Distributing Co.
NEW ORLEANS
C. T. Patterson Co., Inc.
NEW ROCHELLE, N. Y.
Appliance Distributors, Inc.
OMAHA
Russell Harris, Inc.
PEORIA
Graybar Electric Co.
PHILADELPHIA
Philadelphia Distributors
PHOENIX
Arizona Mercantile Co.
PITTSBURGH
C. R. Rogers Corp.
PORTLAND, ME.
Frank M. Brown Co.
PORTLAND, ORE.
Graybar Electric Co., Inc.
PORTSMOUTH, O.
The Hibbs Hardware Co.
PROVIDENCE
Tracy & Co., Inc.
RALEIGH, N. C.
Blackwood's, Inc.

RAPID CITY, S. D.
Hills Gas & Appliance Co.
RICHMOND, VA.
Consolidated Sales Co., Inc.
RENO
Bender Warehouse Co.
ROANOKE, VA.
Cormell-Priddy, Inc.
ROCHESTER, MINN.
So. Minnesota Supply Co.
ST. LOUIS
Fridley Brothers, Inc.
SALT LAKE CITY
Graybar Electric Co., Inc.
SEATTLE, Graybar Electric Co.
SIOUX FALLS
Rudning-Robertson Co.
SOUTH BEND, IND.
Andrews Distributing Co., Inc.
SPOKANE
Graybar Electric Co.
SPRINGFIELD, MO.
Harry Cooper Supply Co.
TACOMA
Graybar Electric Co., Inc.
TOLEDO, Scott Sales Co.
TULSA, Looboye, Inc.
UTICA, N. Y.
Miller Electric Co., Inc.
WHEELING, W. VA.
Ott-Heiskell Co.
WICHITA
Wichita Building Material Co.
WICHITA FALLS
White's Auto Stores
WILKES-BARRE, Kile-Jacobs, Inc.
YPSILANTI
Silkworth's Distributors, Inc.

Stewart-Warner Electric, Division of the Stewart-Warner Corporation, Chicago 14 • AM Radio FM • Radio-Phonographs • Television



RCA's new 1949 Movement and Inventory Guide helps you achieve a much larger turnover. Ask your RCA Tube Distributor for a copy.

More profit for you in the complete line of RCA tubes

AM, FM, or TV... practically every make and model receiver you're called upon to service can be completely re-equipped with RCA tubes... from glass, metal and the latest miniatures to television kinescopes. Your RCA Distributor carries extensive stocks for your convenience.

Having the tubes your customers need... and the brand they prefer... means more business for you—from more people!

Keep up-to-date... ask your RCA Distributor for the following bulletins:

- *Receiving Tubes for AM, FM, and Television Broadcast (1275-D)*
- *Receiving Tube Manual (RC-15)*
- *Receiving Tube Price List (2F215R7)*
- *New 1949 Movement & Inventory Guide (2FR933)*



**STOP 1 IN 4
AND MAKE MUCH MORE!**

Proved traffic stopper is this "Top Performers" display in full colors—part of a new Display Service. Ask your RCA Distributor for the latest flyer "Stop 1 in 4 and Make Much More," for complete story.

ALWAYS KEEP IN TOUCH WITH YOUR RCA TUBE DISTRIBUTOR



TUBE DEPARTMENT

RADIO CORPORATION of AMERICA

HARRISON, N. J.