

How to physically install, set jumper settings, and set up a Serial ATA, EIDE, or SSD drive in Windows

Physical Installation:



Critical: Hard drives and Solid State drives (SSD) are highly sensitive precision instruments that read, write, and store information. Special handling is required to protect hard drives from damage. Hard drives can be damaged by Electrostatic Discharge (ESD). Before handling, please use a grounding strap to protect your hard drive and other electronic computer equipment from ESD damage.

1. Turn the system's power off

2. Mount the drive in the system

- **Desktop Drives:** The drive can be mounted in a standard 3.5" device bay. The drive can be mounted sideways, on end, or even upside down as long as the mounting screws are used properly. Use either the four bottom screws or four of the side mounting screws to support the drive. This will prevent vibration and provide additional electrical grounding.
- **Mobile Drives:** Mobile drive installation will vary based on the manufacturing of the system it is being placed in. Please contact your system manufacturer for instructions on mounting your drive in your system.

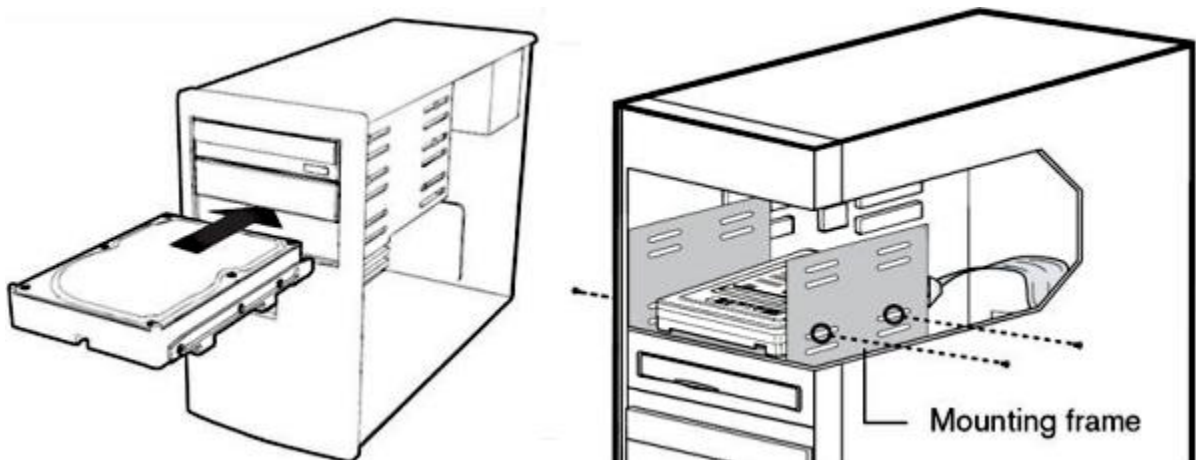

3. Set the jumpers

Jumper settings will vary, depending on the drive model. There is generally no need to change the default jumper setting in order to use the drive. **Your drive's label will show the exact jumper settings your drive supports.** See the images below for examples of our most common jumper settings.

Serial ATA (SATA) I, II, and 6 Gb/s Hard Drive Jumper Settings for 3.5" drives:



Important: Caviar Black drives that have a model number of WD1002FAEX-00Y9A0 use the SATA 3.0 Gb/s pin layout - setting Jumpers 5 & 6 on these model drives will enable OPT1 which will set your drive to 1.5 Gb/s. Please [Contact Us](#) with any questions or issues with the jumper settings on this model drive.

Jumper Settings for SATA 3.0 Gb/s 3.5" Hard Drives and Caviar Black WD1002FAEX-00Y9A0 SATA 6.0 Gb/s Hard Drives:

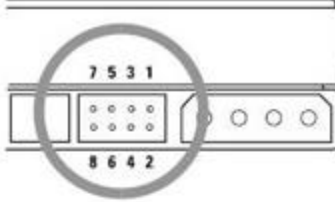
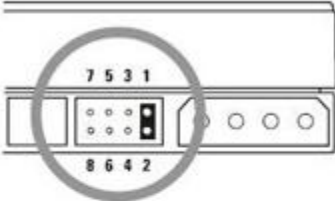
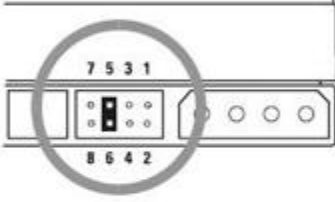
	Default Standard configuration (no jumper added). Spread spectrum clocking (SSC) and OPT1 disabled.
	SSC enabled SSC enabled (jumper on pins 1-2).
	OPT1 enabled OPT1 enabled (jumper on pins 5-6). 1.5 Gb/s data transfer speed activated.

Jumper Settings For SATA 6.0 Gb/s 3.5" Hard Drives:

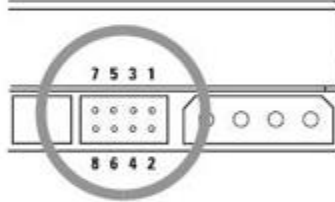
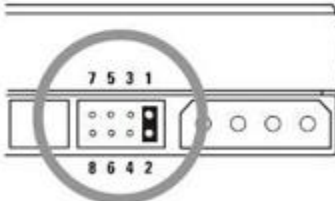
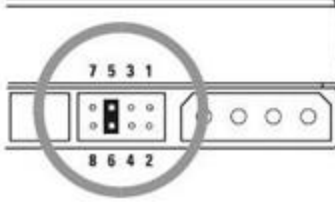
	Default Standard configuration (no jumper added). Spread spectrum clocking (SSC) and PHY disabled.
	SSC enabled SSC enabled (jumper on pins 1-2).
	PHY enabled PHY enabled (jumper on pins 5-6) 3.0 Gb/s data transfer speed activated

Advanced Format Special Jumper Setting: (for select 3.5" ADF drives only)

Advanced Format Jumper Setting

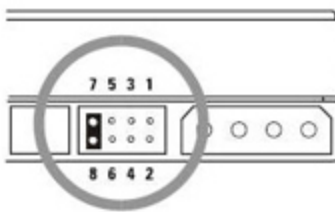

Adv Format

Advance Format Drives - To achieve full performance on Windows XP, single partition, set Jumpers 7-8 prior to installation

SATA Mobile Hard Drive Jumper Settings:

KEY: ◻ ◻ Jumper pins ◼ ◼ Jumper added

- 1** Standard configuration (no jumper added—spread spectrum clocking and RPS disabled),

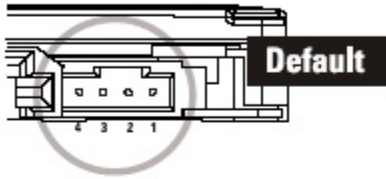

- 3** RPS enabled. (Reduced Power Spinup)

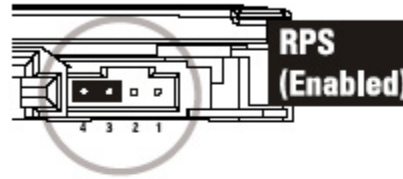

- 2** Spread spectrum clocking enabled.

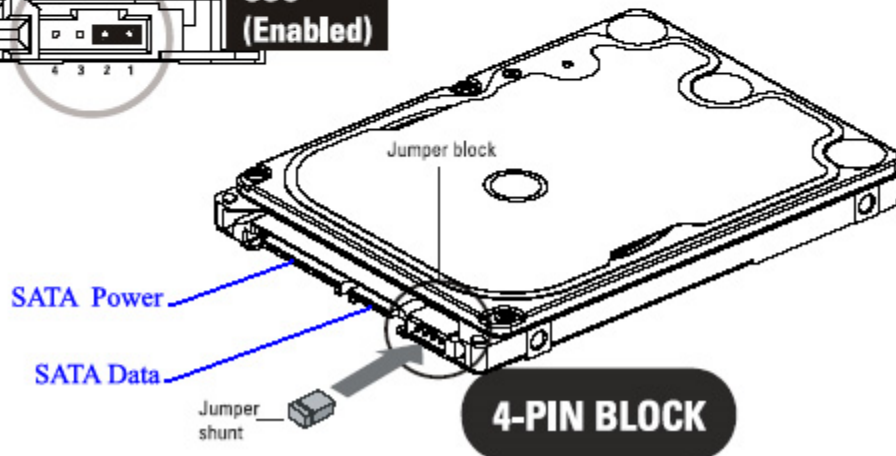
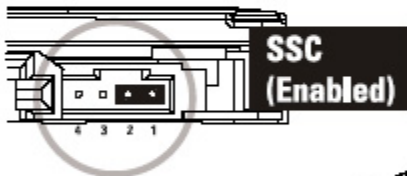

EIDE (PATA) Desktop Hard Drive Jumper Settings:

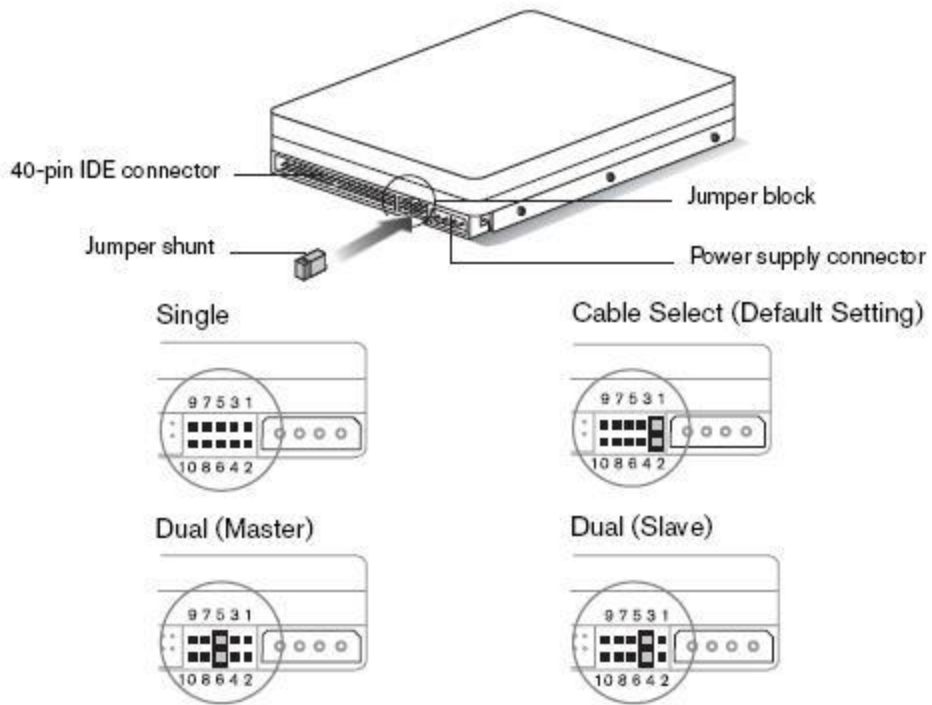

EIDE (PATA) Mobile Hard Drive Jumper Settings:

4. **Attach the power supply cable**

To supply power to the drive you may use either the SATA power connector or the legacy ATA-4-pin (Molex) power connector on the back of the drive (see image below).



Important: If your drive has both power connectors, do not connect both the SATA and the legacy ATA power cable to the drive at the same time. This may result in damage to the drive.

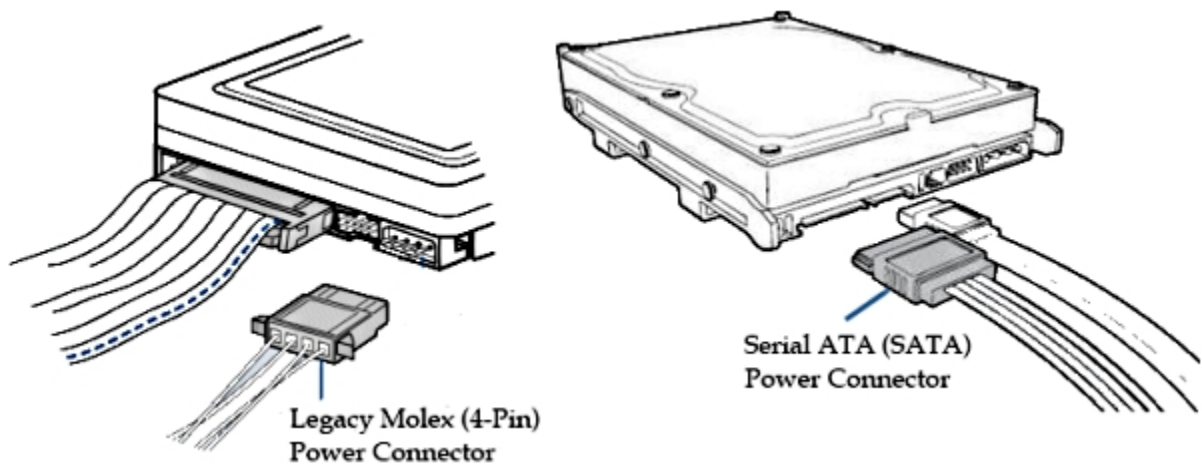

5. Attach the EIDE (PATA) or SATA interface cable:

SATA Drives:

The drive can be configured in one of two ways:

- Connected to a SATA host adapter card installed to the system.
- Connected directly to a Serial ATA connector on the motherboard

Unlike EIDE cables, either end of a standard SATA cable can be connected to the drive. Once you have connected the cable to the drive, connect the other end into the SATA host adapter card, or the motherboard. SATA interface cables have keyed connectors to prevent incorrect installation. Make sure the cable is no longer than 39 inches to minimize line noise and to remain within the SATA specification.

(This illustration shows the drive being connected the motherboard.)

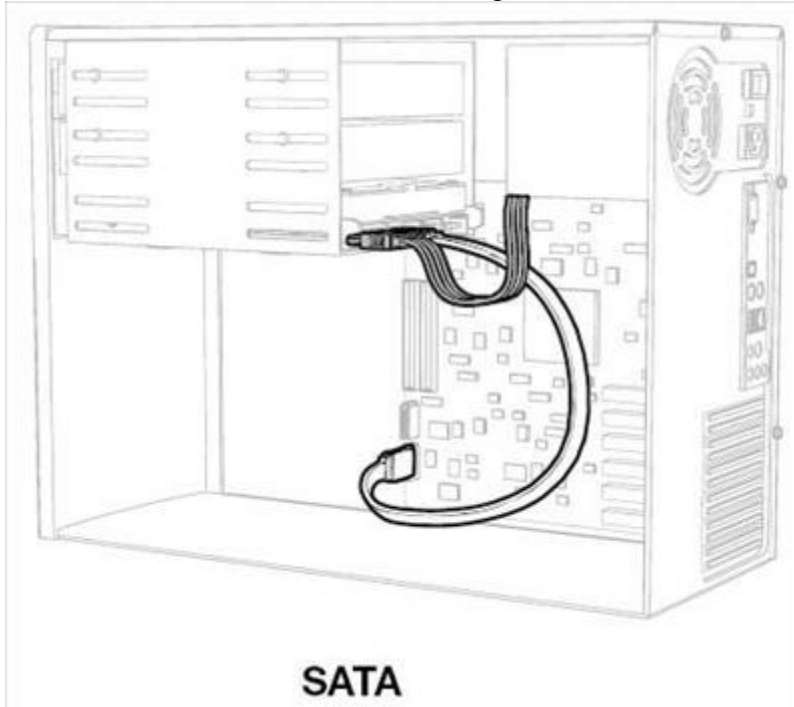

EIDE (PATA) Drives:

- **Connect the EIDE (PATA) Interface Cable to the hard drive(s):**
 - a. If installing the hard drive as the only drive on the cable:
Connect the black connector of the EIDE (PATA) interface cable to the drive.
 - b. If installing two drives on the same EIDE (PATA) interface cable:
Jumper the bootable drive as Master, and the other drive as Slave; then connect the Master drive to the black connector of the EIDE (PATA) interface cable, and the Slave drive to the gray connector.

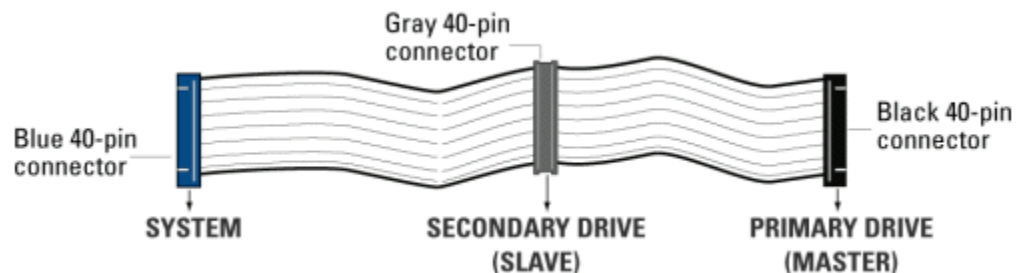

- **Connect the IDE Interface Cable to the Motherboard:**
Attach the blue end of the IDE interface cable to the 40-pin connector on the motherboard. Match pin 1 on the IDE interface cable to the connector on the motherboard.

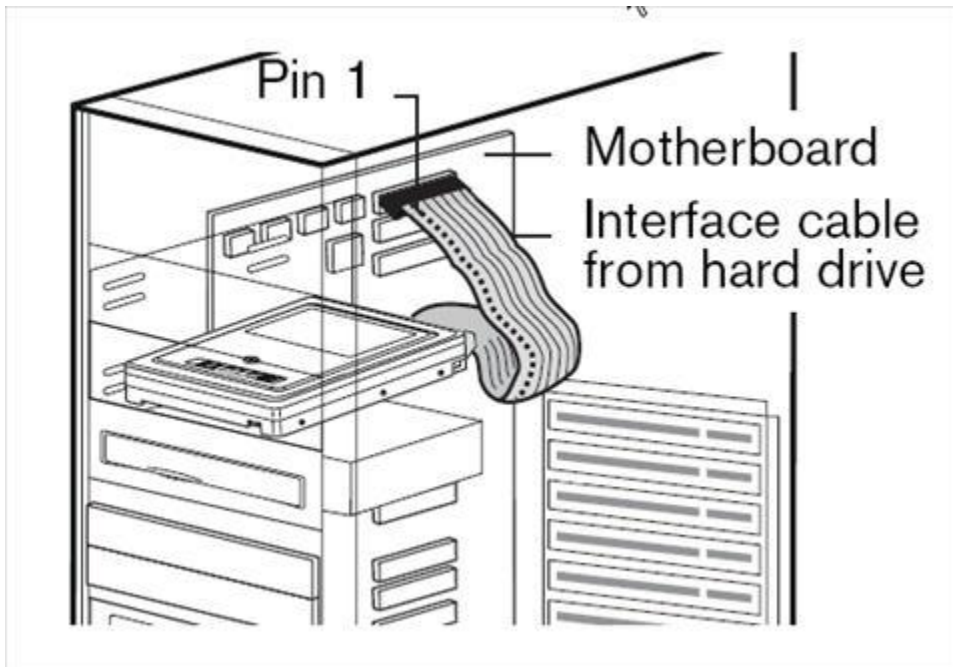

6. Power On Your Computer

1. Replace the system cover, reconnect the power cord, and power on the system. At startup, the computer will display all the devices detected on the system.
2. If the drive you installed is not detected, restart the computer.
3. At startup, run the CMOS Setup program and configure your BIOS so your drive is detected. Your system or motherboard manual should provide these instructions. If it does not you will need to contact your system or motherboard manufacturer for assistance.

4. Restart the system to make sure the drive is detected.
5. Install your Operating System, or configure your Operating System to see your drive. See the information below for assistance performing this step:

Operating System Installation

Once a WD hard drive or SSD is installed in a system, the next step is often to install an Operating System. The instructions below outline how to configure a drive during the installation processes of various Operating Systems. This information is provided as a convenience to our customer - for technical assistance installing an OS, you will need to contact either your system manufacturer or the publisher of your OS (For Windows you would contact [Microsoft Support](#)).

Please select an Operating System below to jump to its installation instructions:

- [Windows 7](#)
- [Windows Vista](#)
- [Windows XP](#)
- [Windows 2000](#)
 - [Installing a SATA Hard Drive on Windows 2000](#)
 - [Installing an EIDE \(PATA\) Hard Drive on Windows 2000](#)
- [Unix/Linux \(Any Distribution\)](#)

Windows 7

The Windows 7 Operating System has all the necessary tools to properly install a Serial ATA (SATA) hard drive, EIDE hard drive, or Solid State drive (SSD). Please follow the appropriate step-by-step instructions for your installation below. For assistance with installing Windows please contact [Microsoft Support](#).

Primary (C:) drive installation during Windows 7 setup:

1. Make sure your drive is detected by your controller or in BIOS during bootup. Please disconnect any other hard drives from the computer system until Windows has been completely installed on the desired hard drive.



Note: If your controller supports RAID, you may need to define your drive in a RAID Array before Windows will see the drive, even if the motherboard or system drivers are being loaded correctly. This may still occur even if you are installing a single drive. Please contact your system or RAID controller manufacturer for assistance on defining your drive in a RAID Array.

2. Insert the Windows 7 DVD into the DVD-ROM drive and restart the system.

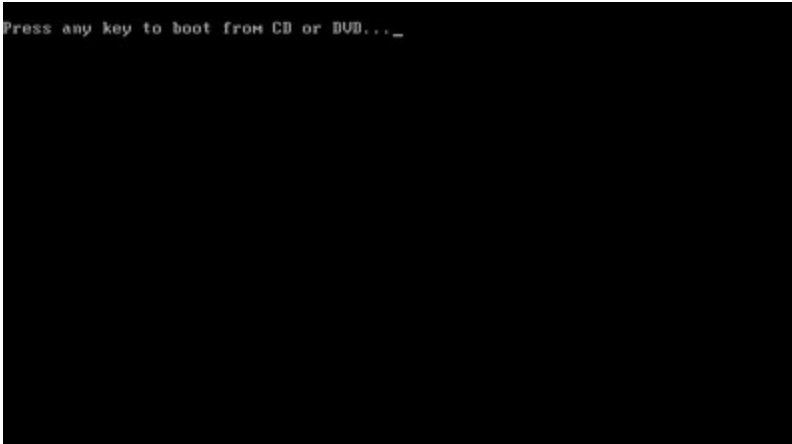

3. Follow the onscreen prompts until the screen **Where do you want to install Windows?** is displayed.

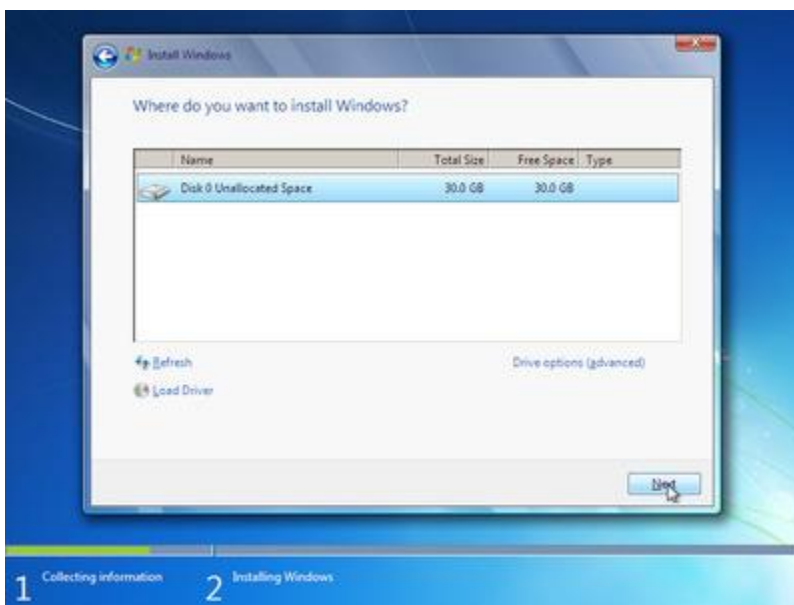

4. You should see your hard drive listed as Unallocated Space.
5. If you want a single partition (single drive letter), click on **Next** and your hard drive will be automatically partitioned and formatted as NTFS and Windows 7 will continue installing. Western Digital highly recommends partitioning your drive in this manner.
6. If you want multiple partitions on this hard drive see the additional instructions below:

Adding Multiple Partitions to your Boot Drive during a Windows 7 Installation:



Important: Western Digital Technical Support can only assist with issues when a drive is formatted with a single partition.

1. Click on **Drive options (advanced)**.
2. Click on **New** to add a new partition to the hard drive.
3. Input the capacity of the partition and click on the **Apply** button.
4. If you wish to add another partition to the drive, select the **Disk 0 Unallocated Space** again and click on **New** to add another new partition to the hard drive.
5. Input the capacity of the partition and click on the **Apply** button.

6. Continue steps 4 and 5 until the desired amount of partitions is obtained and then click on **Next** to continue installing Windows 7 on the first partition.
-

Adding an additional hard drive to a Windows 7 installation:

7. Make sure your hard drive is detected by your Serial ATA or EIDE controller. If it does not verify the connections are secure. If the drive still is not detected after testing the cables, contact your controller card manufacturer to see if there is an update available.
 8. Start Windows 7 and allow the Operating System to boot to the desktop.
 9. Follow the instructions in [Answer ID 8200: How to Partition and Format a WD Drive on Windows and macOS](#) for Windows 7.
 10. Once your drive has been partitioned and format verify it appears under **My Computer**.
-

Windows Vista

The Windows Vista Operating System has all the necessary tools to properly install a Serial ATA (SATA) hard drive, EIDE hard drive, or Solid State drive (SSD). Please follow the appropriate step-by-step instructions for your installation below. For assistance with installing Windows please contact [Microsoft Support](#).

Primary (C:) drive installation during Windows Vista setup:

1. Make sure your drive is detected by your controller or in BIOS during bootup. Please disconnect any other hard drives from the computer system until Windows has been completely installed on the desired hard drive.



Note: If your controller supports RAID, you may need to define your drive in a RAID Array before Windows will see the drive, even if the motherboard or system drivers are being loaded correctly. This may still occur even if you are installing a single drive. Please contact your system or RAID controller manufacturer for assistance on defining your drive in a RAID Array.

2. Insert the Windows Vista CD or DVD into the CD-ROM or DVD-ROM drive and restart the system.

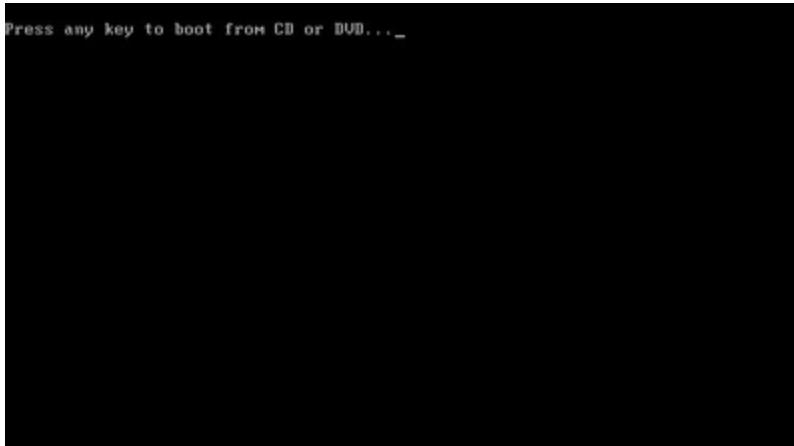

3. Follow the onscreen prompts until the screen **Where do you want to install Windows?** is displayed.

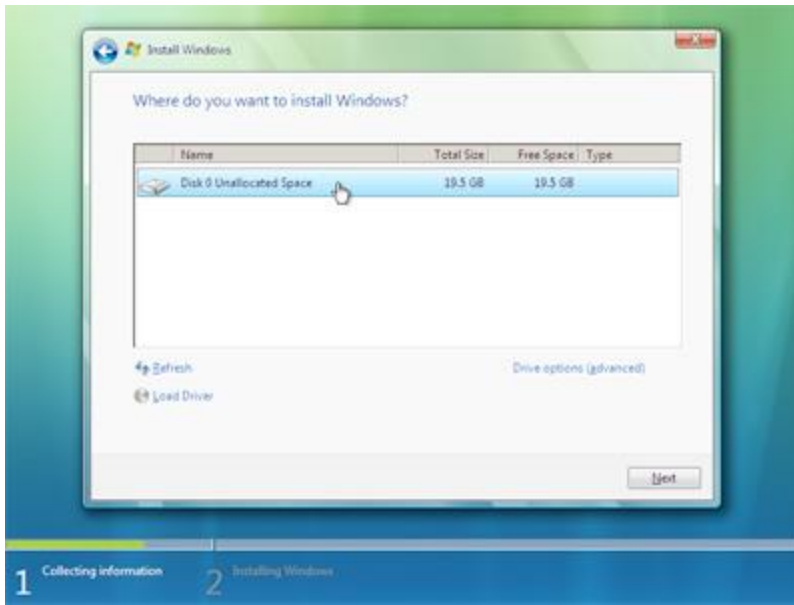

4. You should see your hard drive listed as Unallocated Space.
5. If you want a single partition (single drive letter), click on **Next** and your hard drive will be automatically partitioned and formatted as NTFS and Windows Vista will continue installing. Western Digital highly recommends partitioning your drive in this manner.
6. If you want multiple partitions on this hard drive see the additional instructions below:

Adding Multiple Partitions to your Boot Drive during a Windows Vista Installation:



Important: Western Digital Technical Support can only assist with issues when a drive is formatted with a single partition.

1. Click on **Drive options (advanced)**.
2. Click on **New** to add a new partition to the hard drive.

3. Input the capacity of the partition and click on the **Apply** button.
 4. If you wish to add another partition to the drive, select the **Disk 0 Unallocated Space** again and click on **New** to add another new partition to the hard drive.
 5. Input the capacity of the partition and click on the **Apply** button.
 6. Continue steps 4 and 5 until the desired amount of partitions is obtained and then click on **Next** to continue installing Windows Vista on the first partition.
-

Adding an additional hard drive to a Windows Vista installation:

1. Make sure your hard drive is detected by your Serial ATA or EIDE controller. If it does not verify the connections are secure. If the drive still is not detected after testing the cables, contact your controller card manufacturer to see if there is an update available.
 2. Start Windows Vista and allow the Operating System to boot to the desktop.
 3. Follow the instructions in [Answer ID 8200: How to Partition and Format a WD Drive on Windows and macOS](#) for Windows Vista.
 4. Once your drive has been partitioned and format verify it appears under **My Computer**.
-

Windows XP



Critical: Windows XP is no longer supported by Western Digital Technical Support. If you need assistance with your drive you will need to connect the drive to a computer running a supported operating system prior to calling or emailing our support team.

The Windows XP Operating System has all the necessary tools to properly install a Serial ATA (SATA) hard drive, EIDE hard drive, or Solid State drive (SSD). Please follow the appropriate step-by-step instructions for your installation below. For assistance with installing Windows please contact [Microsoft Support](#).

Primary (C:) drive installation during Windows XP setup:

1. Make sure your drive is detected by your controller or in BIOS during bootup. Please disconnect any other hard drives from the computer system until Windows has been completely installed on the desired hard drive.



Note: If your controller supports RAID, you may need to define your drive in a RAID Array before Windows will see the drive, even if the motherboard or system drivers are being loaded correctly. This may still occur even if you are installing a single drive. Please contact your system or RAID controller manufacturer for assistance on defining your drive in a RAID Array.

2. Insert the Windows XP CD into the CD-ROM drive and restart the system

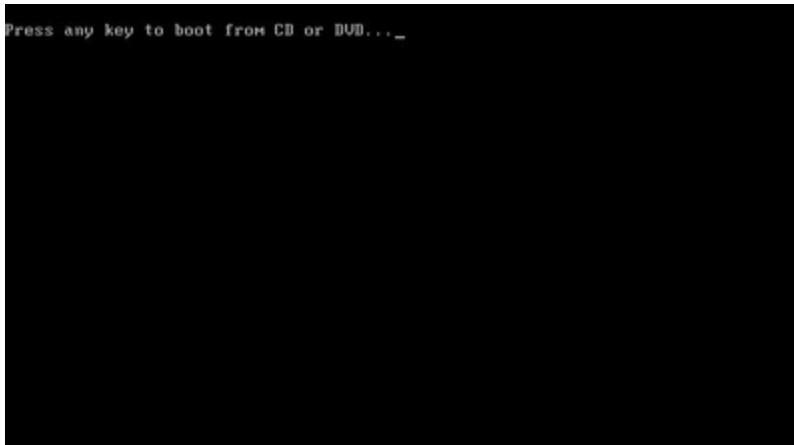

3. Follow the onscreen prompts until the partition list screen is displayed



4. You should see your hard drive listed as **Unpartitioned Space**. Highlight this space with the **Arrow Keys** and press the **C** button on your keyboard.

5. Windows will show the size of the hard drive and ask how much space you would like to assign to the partition. If you want a single partition (single drive letter), select all the available disk space. **Having a single partition on your boot drive is highly recommended by Western Digital, and is required to receive technical support for the drive.** Finally highlight this partition and press the **ENTER** button on your keyboard to begin installing Windows XP.

6. If you plan on creating multiple partitions, select only the amount of space you would like on your C: partition.

7. If you want multiple partitions on this hard drive see the additional instructions below:

Adding Multiple Partitions to your Boot Drive during a Windows XP Installation:



Important: Western Digital Technical Support can only assist with issues when a drive is formatted with a single partition.

1. You should already have your primary (C:) partition defined with extra space left over as **Unpartitioned Space**. Highlight the **Unpartitioned Space** and press the C button.
2. Select the amount of space you would like on your second partition.
3. If there is space left over and you would like to create another partition select **Unpartitioned Space** again and press the C button on your keyboard.
4. Select the amount of space you would like to use for this partition.
5. Continue steps 3 and 4 until the desired amount of partitions is obtained.
6. Select your primary (C:) partition and press **ENTER** on your keyboard to begin installing Windows XP.

Adding an additional hard drive to a Windows XP installation:

1. Make sure your hard drive is detected by your Serial ATA or EIDE controller. If it does not verify the connections are secure. If the drive still is not detected after testing the cables, contact your controller card manufacturer to see if there is an update available.
2. Start Windows XP and allow the Operating System to boot to the desktop.
3. Follow the instructions in [Answer ID 8200: How to Partition and Format a WD Drive on Windows and macOS](#) for Windows XP.

4. Once your drive has been partitioned and format verify it appears under **My Computer**.
-

Windows 2000



Critical: Windows 2000 is no longer supported by Western Digital Technical Support. If you need assistance with your drive you will need to connect the drive to a computer running a supported operating system prior to calling or emailing our support team.

The Windows 2000 Operating System has all the necessary tools to properly install a Serial ATA (SATA) hard drive or EIDE hard drive. **Please note that we do not support our Solid State drives (SSD) on this operating system.** Please follow the appropriate step-by-step instructions for your installation below. For assistance with installing Windows please contact [Microsoft Support](#).

Installing a SATA Hard Drive on Windows 2000:

Single Install:

For proper installation of a drive using Windows 2000, simply allow the operating system to partition and format the drive during the installation process. Step-by-step instructions follow below:

1. Insert the Windows 2000 CD into the CD-ROM drive and restart the system.
2. When installing Windows 2000 to a Serial ATA drive, you may need to specify the SATA controller drivers early on during the installation. For specific details, see [Answer ID 5869: Error: 'No mass storage device found' is reported during installation of Windows](#).
3. During the installation process, you will be given the option to create partitions.
4. Create the partition size you want by pressing **C** when prompted.

5. Continue with the installation of Windows 2000, as instructed by the installation program.



Note: If you are formatting using the FAT32 file system, partitions cannot be larger than 32GB. For additional information on this limitation, please contact [Microsoft Support](#).

Adding Second Drive:

1. Click the **Start button** and then access **Control Panel -> Administrative Tools -> Computer Management -> Storage -> Disk Management**.
2. The Write Signature & Upgrade Wizard displays.



Note: When you see the message, *No signature found on Disk 1*, press **YES**. You must use this wizard to write a Signature to the drive. Otherwise, it will not work in Windows 2000. Drives are numbered as follows: drive 0 being the boot drive and drive 1 and above are all other drives.

Using Write Signature & Upgrade Wizard:

3. Click **Next** on the first screen, and then select the drive you wish to install (in this case Disk 1).
4. Select the drive you are writing the signature to.
5. On the next screen, select the drive you are upgrading/installing. The next screen shows the drive you have selected to write the signature to (if this is a new drive install only a signature will be written, making the drive a **Basic Disk**).

Partitioning/Formatting:

6. Once the above step is complete, right-click in the unallocated space of the drive.

7. Click on **Create Partition**. The Create Partition wizard is displayed. Click **Next** to continue.
8. On the next screen select **Primary, Extended or a Logical Partition** and click **Next** to continue.
9. Assign a drive letter not in use by other devices. Click **Next** to continue.
10. Select the type of format (NTFS or FAT32). Leave allocation unit size at default and label the drive as desired.
11. Edit the partition size. If using FAT32, don't create anything larger than 32GB.
12. Click **Finish** when complete.



Note: If you are formatting using the FAT32 file system, partitions cannot be larger than 32GB. For additional information on this limitation, please contact [Microsoft Support](#).

Installing an EIDE (PATA) hard drive on Windows 2000:

Verify the following prior to installing the drive in Windows 2000:

- You will need your Windows 2000 CD-ROM (if installing a single drive).
- Make sure that your system BIOS is properly configured. See below:

BIOS Settings

Typically, a message is displayed on the screen after the memory count of the boot process

telling you how to enter Setup (system BIOS). Different BIOSs may be configured differently, but the primary keystrokes used to enter the system BIOS are F1, F2 or Delete. For additional commonly used commands to access your BIOS, see For specific information on how to enter your system BIOS and make the necessary changes referred to above, please consult your motherboard or system manual, or the manufacturer directly.

Set the system BIOS to auto detect the drive with LBA mode enabled. Older systems may hang or freeze while auto detecting large capacity drives. If this situation occurs, set the drive to **User** and enter 1023 for **Cylinders**, 16 for **Heads**, 63 for **Sectors**, and disable **LBA mode**. Your BIOS may have more settings than Cylinders, Heads, and Sectors; if so, simply enter 0 for them. For other options see .

Single Install:

For proper installation of a drive using Windows 2000, simply allow the operating system to partition and format the drive during the installation process. Step-by-step instructions follow below.

1. Make sure that your drive is recognized by the BIOS.



Note: Users installing an ATA/100 drive: Windows 2000 by default does not support ATA/100 data transfer rates. Microsoft has added support for ATA/100 in Windows 2000 with the release of Service Pack 2. This can be installed once Windows 2000 is loaded on the drive. If you are experiencing any issues during Windows installation, disable UDMA mode in the system BIOS. Once the installation is complete and you have installed Service Pack 2, enable UDMA again.

2. Insert the Windows 2000 CD into the CD-ROM drive and restart the system. During the installation process, you will be given the option to create partitions.
3. Create the partition size you want by pressing **C** when prompted.
4. Continue with the installation of Windows 2000, as instructed by the installation program.



Note: If you are formatting using the FAT32 file system, partitions cannot be larger than 32 GB. For additional information on this limitation, contact [Microsoft Support](#).



Important: Multiple partitions can be created during Windows installation, but the partitions that do not contain Windows cannot be formatted until Windows is completely installed on the hard drive. Once Windows is installed, opening "My Computer" will display the additional partitions as drive letters. You can **Right-Click** on these drive letters and choose to **Format** these drives from the menu shown. A full format must be performed during this action.

Adding Second Drive:

1. Make sure that your drive is recognized by the BIOS.



Note: Users installing an ATA/100 drive: Windows 2000 by default doesn't support ATA/100 drives. To resolve this issue please download and install the latest [Microsoft Service Pack](#).

2. Click the **Start button** and then access **Control Panel ->Administrative Tools -> Computer Management -> Storage -> Disk Management**.
3. The Write Signature & Upgrade Wizard displays.



Note: When you see the message, *No signature found on Disk 1*, press **YES**. You must use this wizard to write a Signature to the drive. Otherwise, it will not work in Windows 2000. Drives are numbered as follows: drive 0 being the boot drive and drive 1-3 are all other drives.

Using Write Signature & Upgrade Wizard:

4. Click **Next** on the first screen, select the drive you wish to install(in this case Disk 1).
5. Select the drive you are writing the signature to.

6. On the next screen, select the drive you are upgrading/installing. The next screen shows the drive you have selected to write the signature to (if this is a new drive install only a signature will be written, making the drive a **Basic Disk**).



Note: When you upgrade the disk, you change it from a **Basic Disk** to a **Dynamic Disk**. This allows the drive to be used in a RAID configuration and a signature to be written to it from operating system.

Partitioning/Formatting:



Note: In two separate windows, on the right side of the screen, a graphical representation of the partitions on the installed drives will be displayed. The top window is for viewing a drive's status, capacity, and file system. In the bottom window, you will see a representation of the drives in the system starting with the boot drive (drive 0). In almost all cases, you will want to work with the bottom window.

1. Once the disk is initialized, right-click in the **unallocated** space.
2. Left-click on **Create Partition** from the menu.
3. A new wizard will appear: **Create Partition Wizard**. Left-click on **Next** to continue.
4. On the next screen select either **Primary** or **Extended** Partition and left-click on **Next** to continue.



Important: Each physical hard drive can contain up to four **Primary Partitions**, or three **Primary Partitions**, and **Extended Partitions** containing **Logical Drives**. For more information about **Primary Partitions**, **Extended Partitions**, and **Logical Drives** please see [Microsoft's Knowledge Base](#).

5. Enter the desired partition size. If using FAT32, your partition cannot be larger than 32GB. Left-click on **Next** to continue.

6. You may assign a drive letter that is not in use by other devices if you wish, then left-click on **Next** to continue.

7. Select the type of format (NTFS or FAT32). Leave the allocation unit size at default and label the drive as desired. Select the checkbox labeled **Perform a quick format** and then left-click on **Next** to continue.

8. Left-click on **Finish** when done.



Note: If you are formatting using the FAT32 file system, partitions cannot be larger than 32 GB. For additional information on this limitation, please contact [Microsoft Knowledge Base Article 184006](#).

Unix/Linux (Any Distribution)

Western Digital technical support only provides jumper configuration (for EIDE hard drive) and physical installation support for hard drives used in systems running the Linux/Unix operating systems. For setup or other questions beyond physical installation of your Western Digital hard drive, please contact your Linux/Unix vendor.